

# 4061 FOLD-UP FLOOR SLAB BRACKET

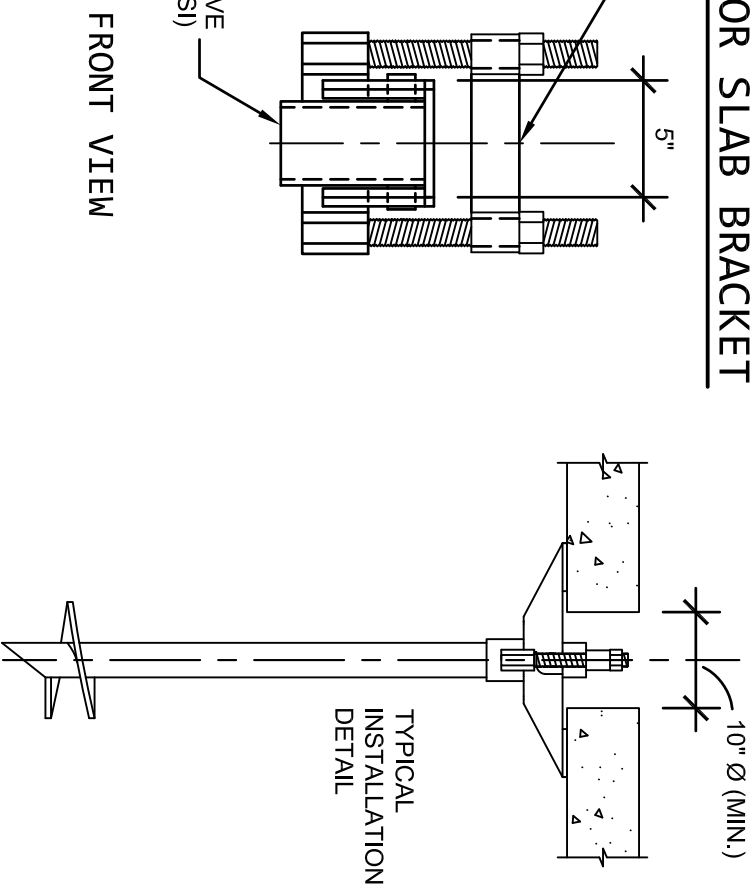
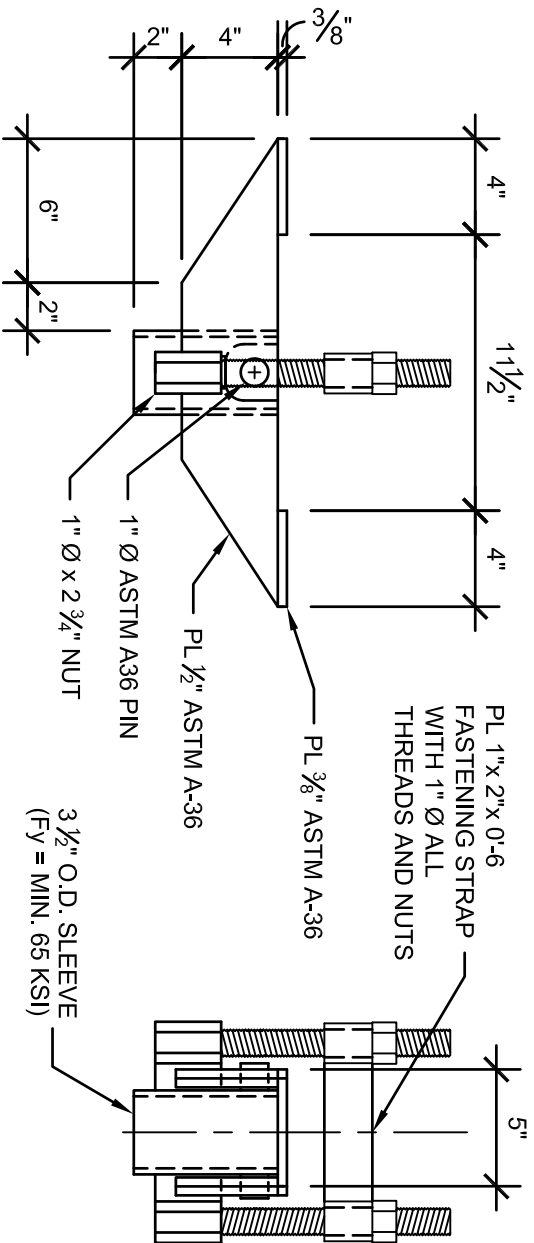

## NOTES:

- POLYETHYLENE COPOLYMER THERMOPLASTIC COATING PER ICC-ES AC 228
- REFERENCE PRE-CONSTRUCTION BRACKET CHART FOR ALLOWABLE LOAD CAPACITY OF BRACKET ONLY.
- MANUFACTURER TO HAVE IN EFFECT INDUSTRY RECOGNIZED WRITTEN QUALITY CONTROL FOR ALL MATERIALS AND MANUFACTURING PROCESSES.
- ALL WELDING IS TO BE DONE BY WELDERS CERTIFIED UNDER SECTION 5 OF THE AWS CODE D1.1.
- THE CAPACITY OF THE UNDERPINNING SYSTEM IS A FUNCTION OF MANY INDIVIDUAL ELEMENTS, INCLUDING THE CAPACITY OF THE FOUNDATION, BRACKET, PIER SHAFT, HELICAL PLATE, AND BEARING STRATA, AS WELL AS THE STRENGTH OF THE FOUNDATION BRACKET CONNECTION AND THE QUALITY OF THE INSTALLATION OF THE PILE. YOUR ACHIEVABLE CAPACITIES COULD BE HIGHER OR LOWER THAN THOSE LISTED DEPENDING ON THE ABOVE FACTORS.
- SEE ICC-ES EVALUATION REPORT PFC-5996 AND RAM JACK ENGINEERING HANDBOOK FOR ALLOWABLE VALUES AND/OR CONDITIONS OF USE CONCERNING MATERIAL PRESENTED IN THIS DOCUMENT.
- PUNCHING SHEAR OF SLAB MUST BE CHECKED. \*PUNCHING SHEAR NORMALLY DETERMINES PILE SPACING.

## ALLOWABLE LOAD CHART

| PART NUMBER | DIAMETER OF PILE | ALLOWABLE LOAD CAPACITY | BEARING PLATE AREA (IN <sup>2</sup> ) |
|-------------|------------------|-------------------------|---------------------------------------|
| 4061.2375   | 2 3/8"           | 15.0 KIPS               | 40 IN <sup>2</sup>                    |
| 4061.2875   | 2 7/8"           | 20.0 KIPS               | 40 IN <sup>2</sup>                    |

\* BRACKET WITH 2 3/8" PILE REQUIRES A 2 7/8" x 1'-0" SLEEVE IN BRACKET.



# RAM JACK

|                      |          |                          |              |        |
|----------------------|----------|--------------------------|--------------|--------|
| FOLD UP SLAB BRACKET |          | CATALOG NO. : SEE TABLES |              | REV. 1 |
| SCALE                | DRAWN BY | DATE                     | SHEET 1 OF 1 |        |
| 1 1/2" = 1'-0"       | DLW      | 04/30/08                 |              |        |