

ICC-ES Evaluation Report

ESR-1854

Issued February 1, 2011

This report is subject to re-examination in one year.

www.icc-es.org | (800) 423-6587 | (562) 699-0543

A Subsidiary of the International Code Council®

DIVISION: 31 00 00—EARTHWORK
Section: 31 63 00—Bored Piles

REPORT HOLDER:

GREGORY ENTERPRISES, INC.
3065 FOREST LANE
GARLAND, TEXAS 75042
(972) 494-3800
www.ramjack.com
steve@ramjack.com

ADDITIONAL LISTEE:

RAM JACK MANUFACTURING LLC
13655 COUNTY ROAD 1570
ADA, OKLAHOMA 74820

EVALUATION SUBJECT:

RAM JACK® FOUNDATION SYSTEMS

1.0 EVALUATION SCOPE

Compliance with the following code:

2006 International Building Code (IBC)

Property evaluated:

Structural

2.0 USES

Ram Jack® Foundation Systems include a helical pile system and a hydraulically driven steel piling system. The helical pile system is used to transfer compressive, tension, and lateral loads from a new or existing structure to a soil suitable for the applied loads. The hydraulically driven steel piling system is used to transfer compressive loads from existing foundations to load-bearing soil strata that are adequate to support the downward-applied compression loads. Brackets are used to transfer the loads from the building foundation to the helical pile system or the hydraulically driven steel piling system.

3.0 DESCRIPTION

3.1 General:

The Ram Jack® Foundation Systems consist of either helical piles or hydraulically driven steel pilings connected to brackets that are in contact with the load-bearing foundation of a structure.

3.2 System Components:

3.2.1 Helical Pile System—Lead Shafts and Extensions: The lead shafts consist of 2⁷/₈-inch-outside-

diameter (73 mm) steel pipe having a shaft thickness of 0.217 inch (5.5 mm). Helical-shaped discs, welded to the pipe, advance the helical piles into the soil when the pile is rotated. The helical discs (plates) are 8, 10, 12 or 14 inches (203, 254, 305 or 356 mm) in diameter, and are cut from 3⁷/₈-inch- or 1¹/₂-inch-thick (9.5 or 12.7 mm) steel plate. The helical plates are pressed, using a hydraulic press and die, to achieve a 3-inch (76 mm) pitch, and are then welded to the helical lead shaft. Figure 1 illustrates a typical helical pile. The extensions have shafts similar to the lead sections, without the helical plates. The helical pile lead sections and extensions are connected together by using an internal threaded pin and box system that consists of a box welded into the trailing end of the helical lead section. Each extension consists of a threaded pin and box on opposing ends. Figure 2 illustrates the helical pin and box connections. The lead shafts and extensions are coated with a polyethylene copolymer coating complying with the ICC-ES Acceptance Criteria for Corrosion Protection of Steel Foundation Systems Using Polymer (EAA) Coatings (AC228), and having a minimum coating thickness of 18 mils (0.46 mm) as described in the approved quality documentation.

3.2.2 Hydraulically Driven Pile System—Pilings, Connectors, Starter, and Guide Sleeve:

The pilings consist of 2⁷/₈-inch-outside-diameter (73 mm) pipe having a shaft thickness of 0.217 inch (5.5 mm), in either 3-, 5- or 7-foot-long (914, 1524, or 2134 mm) sections. Connectors used to connect the pilings together are 12-inch-long (305 mm), 2³/₈-inch-outside-diameter (60.3 mm) pipe having a shaft thickness of 0.19 inch (4.8 mm), crimped and inserted in one end of the piling section so that approximately 6 inches (152 mm) of the connector extends out of one end of the piling section. During installation, the subsequent piling section slides over the connector of the previous piling section. Figure 3 illustrates a typical piling used in conjunction with a bracket. The starter consists of a 2⁷/₈-inch-diameter (73 mm) steel pipe having a shaft thickness of 0.217 inch (5.5 mm), and a 2³/₈-inch-outside-diameter (60.3 mm) pipe having a shaft thickness of 0.19-inch (4.8 mm), which is crimped and inserted in one end of the piling section so that approximately 6 inches (152 mm) of the connector extends out of one end of the piling section. A 2³/₈-inch-diameter-by-1¹/₈-inch-thick (3.2 mm by 60.3 mm) ASTM A 36 steel soil plug is welded inside the 2⁷/₈-inch (73 mm) starter section against the 2³/₈-inch (60.3 mm) connector. The starter section is jobsite-installed into the end of the initial piling and leads the piling in order to expand the soil away from the piling with a 3¹/₂-inch-outside-diameter (89 mm) steel ring having a wall thickness of 0.254-inch (6.54 mm), welded to the starter section 1 inch (25.4 mm) from the bottom edge to

reduce skin friction. Figure 4 illustrates a typical starter joint. A steel pipe guide sleeve, shown in Figure 3, is used to laterally strengthen the driven pile. The starter, guide sleeve, and pilings are coated with polymer coating complying with AC228 and having a minimum coating thickness of 18 mils (0.46 mm), as described in the approved quality documentation.

3.2.3 Brackets: Brackets are constructed from steel plate and steel pipe components, which are factory-welded together. The different brackets are described in Sections 3.2.3.1 through 3.2.3.5. All brackets are coated with polymer coating complying with AC228 and having a minimum thickness of 18 mils (0.46 mm), as described in the approved quality documentation.

3.2.3.1 Support Bracket #4021.1: This bracket is used to support existing concrete foundations supporting axial compressive loading. The bracket is constructed of a $\frac{3}{8}$ -inch-thick (9.5 mm) steel plate bent to a 90-degree angle seat measuring 10 inches (254 mm) wide by 9 inches (229 mm) long on the horizontal leg and 7 inches (178 mm) on the vertical leg. The seat is welded to a $4\frac{1}{2}$ -inch-outside-diameter (114 mm) steel bracket sleeve having a wall thickness of 0.438 inch (11 mm). The external guide sleeve, a $3\frac{1}{2}$ -inch-outside-diameter (89 mm) steel pipe having a wall thickness of 0.254 inch (6.5 mm), is inserted through the bracket sleeve. The $2\frac{7}{8}$ -inch-outside-diameter (73 mm) pile is inserted through the external guide sleeve. Once the $2\frac{7}{8}$ -inch-outside-diameter (73 mm) pile has been installed through the external guide sleeve, the pile is cut approximately 6-inches (152 mm) above the bracket. Two 1-inch-diameter (25 mm) all-thread bolts are installed into the matching nuts which are welded to each side of the bracket sleeve. A $\frac{3}{4}$ -inch-thick (19 mm) support strap measuring 5 inches (127 mm) long by 2 inches (51 mm) in width is then placed over the all-thread bolts and centered on top of the pile. The support strap is then attached to the bracket with two 1-inch (25 mm) nuts screwed down on the all-threads. This bracket can be used with both the helical and driven pile systems. Figure 5 shows additional details.

3.2.3.2 Support Bracket #4038.1: This bracket is very similar to the 4021.1 bracket but is designed for lighter loads and is only used with the helical pile system on existing structures to support axial compressive loads. The bracket is constructed of a $\frac{3}{8}$ -inch-thick (9.5 mm) steel plate bent to a 90-degree angle seat measuring 10 inches wide (254 mm) by 9 inches (229 mm) long on the horizontal leg and 7 inches (178 mm) long on the vertical leg. The seat is welded to a $3\frac{1}{2}$ -inch-outside-diameter (89 mm) steel bracket sleeve. The $2\frac{7}{8}$ -inch-outside-diameter (73 mm) pile is inserted through the bracket sleeve. Once the $2\frac{7}{8}$ -inch-outside-diameter (73 mm) pile has been installed, the pile is cut approximately 6 inches (152 mm) above the bracket. Two 1-inch-diameter (25 mm) all-thread bolts are installed in matching nuts which are welded to each side of the bracket sleeve. A $\frac{3}{4}$ -inch-thick (19 mm) support strap is then placed over the all-thread bolts and centered on top of the pile. The support strap is then attached to the bracket with two 1-inch (25 mm) nuts screwed down on the all-threads. Figure 6 shows additional details.

3.2.3.3 Support Bracket #4039.1: This is a low-profile bracket used to underpin existing structures to support axial compressive loads where the bottom of the footing is approximately 6 inches (152 mm) to 10 inches (254 mm) below grade. The bracket is constructed of a $\frac{3}{8}$ -inch-thick (9.5 mm) steel plate measuring 10 inches (254 mm) wide by 6.75 inches (172 mm) long, welded to a $4\frac{1}{2}$ -inch-outside-diameter (114 mm) steel bracket sleeve. The

external guide sleeve, a $3\frac{1}{2}$ -inch-outside-diameter (89 mm) steel pipe, is inserted through the bracket sleeve. The $2\frac{7}{8}$ -inch-outside-diameter (73 mm) pile is inserted through the external guide sleeve. Once the $2\frac{7}{8}$ -inch-outside-diameter (73 mm) pile has been installed, the pile is cut approximately 6 inches (152 mm) above the bracket. Two 1-inch-diameter (25 mm) all-thread bolts are installed in matching nuts which are welded to each side of the bracket sleeve. A $\frac{3}{4}$ -inch-thick (19 mm) support strap is then placed over the all-thread bolts and centered on top of the pile. The support strap is then attached to the bracket with two 1-inch (25 mm) nuts screwed down on the all-threads. This bracket can be used with both the helical and driven pile systems. Figure 7 shows additional details.

3.2.3.4 Slab Bracket #4093: This bracket is used to underpin and raise existing concrete floor slabs to support axial compressive loading. The slab bracket consists of two 20-inch-long (508 mm) steel channels (long channels) spaced $3\frac{1}{2}$ inches (89 mm) apart, with two sets of 6-inch-long (152 mm) channels (short channels) welded flange-to-flange (face-to-face) and then welded to the top side of each end of the long channels. One-quarter-inch-thick-by-4-inch-by-5-inch (6 mm by 102 mm by 127 mm) steel plates are welded on the bottom on each end of the long channels. The bracket sleeve is $3\frac{1}{2}$ -inch-outside-diameter (73 mm) steel tube welded to and centered between the two long channels. Two 1-inch-diameter (25 mm) coupling nuts are welded to the long channels on each side of the bracket sleeve. Once the $2\frac{7}{8}$ -inch-outside-diameter (73 mm) pile has been installed, the pile is cut approximately 6 inches (152 mm) above the bracket. Two 1-inch-diameter (25 mm) all-thread bolts are installed in matching nuts which are welded to each side of the bracket sleeve. A $\frac{3}{4}$ -inch-thick (19 mm) support strap is then placed over the all-thread bolts and centered on top of the pile. The support strap is then attached to the bracket with two 1-inch (25 mm) nuts screwed down on the all-threads. This bracket is only used with the helical pile system. Figure 8 contains additional details.

3.2.3.5 New Construction Bracket #4075.1 and #4079.1: These brackets are used with the helical pile system in new construction where the steel bearing plate of the bracket is cast into the new concrete grade beam, footing or pile cap concrete foundations. The brackets can transfer compression, tension and lateral loads between the pile and the concrete foundation. The only difference between the two brackets is the dimensions of the steel bearing plates. The 4075.1 has a $\frac{5}{8}$ -inch-thick-by-4-inch-wide-by-8-inch-long (15.9 mm by 102 by 203 mm) bearing plate with two predrilled holes. The 4079.1 has a $\frac{5}{8}$ -inch-thick-by-8-inch-wide-by-8-inch-long (16 mm by 203 by 203 mm) bearing plate with four predrilled holes. Each steel bearing plate is welded to a $3\frac{1}{2}$ -inch-outside-diameter (89 mm) steel sleeve with a predrilled $\frac{13}{16}$ -inch-diameter (20.6 mm) hole. The bracket is embedded into the foundation unit to provide the effective cover depth and to transfer the tensile and compressive forces between steel bearing plate and surrounding concrete. The bracket is attached to the pile shaft with either one or two $\frac{3}{4}$ -inch-diameter (19.1 mm) through-bolts, as shown in Table 2 of this report, to complete the transfer of tension forces to the pile shaft. Figure 9 contains additional details.

3.2.3.6 #4550.2875.1 Tieback Bracket Assembly: This assembly is used with a helical pile and is only designed for tension loads. The assembly consists of two major components, a tieback connection with rod and a tieback plate. The tieback connection is a $2\frac{3}{8}$ -inch-diameter (60 mm) steel sleeve with two predrilled holes to accept through-bolts for the connection to the helical pile pipe.

One end of the steel sleeve has a 1¹/₂-inch-diameter (38 mm) nut welded to the sleeve to accept a 1¹/₂-inch-diameter (38 mm) all-thread rod that extends through the wall being supported. The tieback plate is an 8-inch (203 mm) channel with a stiffening plate with a 1⁷/₈-inch-diameter (48 mm) hole in its center. The assembly is secured with a 1¹/₂-inch-by-¹/₂-inch (38 by 12.7 mm) wedge washer and nut. Figure 10 shows additional details.

3.3 Material Specifications:

3.3.1 Helix Plates: The carbon steel plates conform to ASTM A 36, having a minimum yield strength of 50,000 psi (345 MPa) and a minimum tensile strength of 70,000 psi (483 MPa).

3.3.2 Helical Anchor Lead Shafts and Extensions: The lead shafts and extensions are carbon steel round tubes that conform to ASTM A 500, Grade C, having a minimum yield strength of 65,000 psi (448 MPa) and a minimum tensile strength of 80,000 psi (552 MPa).

3.3.3 Piling Sections: The piling sections, connectors, starters and guide sleeves are carbon steel round tube conforming to ASTM A 500, Grade C, having a minimum yield strength of 65,000 psi (448 MPa) and a minimum tensile strength of 80,000 psi (552 MPa).

3.3.4 Brackets:

3.3.4.1 Plates: The ³/₈-inch- and ¹/₂-inch-thick (10 and 12.7 mm) steel plates used in the brackets conform to ASTM A 36, but have a minimum yield strength of 50,000 psi (345 MPa) and a minimum tensile strength of 70,000 psi (483 MPa). The ¹/₄-inch- and ⁵/₈-inch-thick (6.4 and 15.9 mm) steel plates used in the brackets conform to ASTM A 36, having a minimum yield strength of 36,000 psi (248 MPa) and a minimum tensile strength of 60,000 psi (413 MPa).

3.3.4.2 Channels: The steel channel used in the brackets conforms to ASTM A 36, having a having a minimum yield strength of 36,000 psi (248 MPa) and a minimum tensile strength of 60,000 psi (413 MPa).

3.3.5 Sleeves: The carbon steel round tube used in the bracket assembly as a sleeve conforms to ASTM A 500, Grade C, having a minimum yield strength of 65,000 psi (448 MPa) and a minimum tensile strength of 80,000 psi (552 MPa).

3.3.6 Threaded Rods, Bolts and Nuts:

3.3.6.1 Helical Anchors: The threaded pin and box used in connecting helical lead shafts and extensions together conform to ASTM A 322, Grade 4140, having a minimum yield strength of 95,000 psi (655 MPa) and a minimum tensile strength of 148,000 psi (1020 MPa).

3.3.6.2 All Other Fastening Assemblies (Including Brackets): The threaded rods conform to ASTM A 307 and the nuts conform to ASTM A 563. The threaded rods and nuts are Class B hot-dipped galvanized in accordance with ASTM A 153.

4.0 DESIGN AND INSTALLATION

4.1 Design:

4.1.1 Helical Pile: Structural calculations and drawings, prepared by a registered design professional, must be submitted to the code official for each project, based on accepted engineering principles, as described in IBC Sections 1604.4 and 1808. The design method for steel components is Allowable Strength Design (ASD), described in IBC Section 1602 and AISC 360 Section B3.4. The structural analysis must consider all applicable internal forces (shear, bending moments and torsional moments, if

applicable) due to applied loads, structural eccentricity and maximum span(s) between helical foundations. The result of the analysis and the structural capacities must be used to select a helical foundation system. The minimum embedment depth for various loading conditions must be included based on the most stringent requirements of the following: engineering analysis, tested conditions described in this report, site-specific geotechnical investigation report, and site-specific load tests, if applicable. For helical foundation systems subject to combined lateral and axial (compression or tension) loads, the allowable strength under combined loads must be determined using the interaction equation prescribed in Chapter H of AISC 360.

A soils investigation report must be submitted to the code official as part of the required submittal documents, prescribed in IBC Section 106, at the time of permit application. The geotechnical report must include, but not be limited to, all of the following:

1. A plot showing the location of the soil investigation.
2. A complete record of the soil boring and penetration test logs and soil samples.
3. A record of soil profile.
4. Information on groundwater table, frost depth and corrosion-related parameters, as described in Section 5.5 of this report.
5. Soil properties, including those affecting the design such as support conditions of the piles.
6. Allowable soil bearing pressure.
7. Confirmation of the suitability of helical foundation systems for the specific project.
8. Recommendations for design criteria, including but not be limited to, mitigation of effects of differential settlement and varying soil strength; and effects of adjacent loads.
9. Recommended center-to-center spacing of helical pile foundations, if different from spacing noted in Section 5.11 of this report; and reduction of allowable loads due to the group action, if necessary.
10. Field inspection and reporting procedures (to include procedures for verification of the installed bearing capacity, when required).
11. Load test requirements.
12. Any questionable soil characteristics and special design provisions, as necessary.
13. Expected total and differential settlement.
14. The axial compression, axial tension and lateral load soil capacities if values cannot be determined from this evaluation report.

There are four primary structural elements associated with the helical foundation system: Bracket Capacity, Pile Shaft Capacity, Helix Plate Capacity and Soil Capacity. The allowable capacity of an individual helical foundation system or device must be the lowest allowable capacity of the four primary elements.

4.1.1.1 Bracket Capacity: The concrete foundation must be designed and justified to the satisfaction of the code official with due consideration to the eccentricity of applied loads, including reactions provided by the brackets, acting on the concrete foundation. Only localized limit states of supporting concrete including punching shear and concrete breakout have been evaluated in this evaluation report.

The effects of reduced lateral sliding resistance due to uplift from wind or seismic loads must be considered for each project. Reference Table 1 for the allowable bracket capacity ratings.

4.1.1.2 Pile Shaft Capacity: The top of shafts must be braced as described in IBC Section 1808.2.5. In accordance with IBC Section 1808.2.9, any soil other than fluid soil must be deemed to afford sufficient lateral support to prevent buckling of the systems that are braced, and the unbraced length is defined as the length of piles standing in air, water, or in fluid soils plus an additional 5 feet (1524 mm) when embedded into firm soil or an additional 10 feet (3048 mm) when embedded into soft soil. Firm soils must be defined as any soil with a Standard Penetration Test blow count of five or greater. Soft soils must be defined as any soil with a Standard Penetration Test blow count greater than zero and less than five. Fluid soils must be defined as any soil with a Standard Penetration Test blow count of zero [weight of hammer (WOH) or weight of rods (WOR)]. Standard Penetration Test blow count must be determined in accordance with ASTM D 1586. The shaft capacity of the helical foundation systems in fluid soils must be determined by a registered design professional. The following are the allowable stress design (ASD) shaft capacities:

- ASD Compression Capacity: Reference Table 5
- ASD Tension Capacity: 57.5 kips (255.8 kN)
- ASD Lateral: 1.49 kips (6.6 kN)
- Torque Rating: 7,000 ft-lb (9495 N-m)

The elastic shortening/lengthening of the pile shaft will be controlled by the strength and section properties of the 2⁷/₈-inch-diameter (73 mm) piling sections. The elastic deflection of the piling will be limited to 0.009 inch per lineal foot of pile (0.75 mm per meter) for the allowable (compression or tensile) pile capacity of 31.5 kips (140.1 kN). The mechanical properties of the piling section are shown in Table 3 and can be used to calculate the anticipated settlements due to elastic shortening/lengthening of the pile shaft.

4.1.1.3 Helix Plate Capacity: Up to six helix plates can be placed on a single helical pile. The helix plates are spaced three times the diameter of the lowest plate apart starting at the toe of the lead section. For helical piles with more than one helix, the allowable helix capacity for the helical foundation systems and devices, may be taken as the sum of the least allowable capacity of each individual helix. The helix plate ASD capacities are:

- 8 inches diameter by ³/₈ inch thick: ±63.29 kips (282 kN)
- 10 inches diameter by ³/₈ inch thick: ± 55.51 kips (247 kN)
- 12 inches diameter by ³/₈ inch thick: ±39.40 kips (175 kN)
- 14 inches diameter by ¹/₂ inch thick: ±42.07 kips (187 kN)

4.1.1.4 Soil Capacity: The allowable axial compressive or tensile soils capacity can be determined using a soils investigation report or the torque correlation method. The individual bearing method (individual bearing method is defined as the sum of the areas of the helical bearing plates times the ultimate bearing capacity of the soil or rock comprising the bearing stratum, divided by a safety factor of 2) must be used by a registered design professional when the appropriate soils information is available for the site. In cases where the soil boring does

not extend to a suitable bearing stratum for the piles to bear in or there is no soils report available, the torque correlation method must be used to determine the ultimate capacity (Q_{ult}) of the pile and the minimum installation torque (Equation 1). A factor of safety of 2 must be applied to the ultimate capacity to determine the allowable soil capacity (Q_{all}) of the pile (Equation 2).

$$Q_{ult} = K_t T \quad (\text{Equation 1})$$

$$Q_{all} = 0.5 Q_{ult} \quad (\text{Equation 2})$$

where:

$$K_t = \text{Torque correlation factor of } 9 \text{ ft}^{-1} \text{ (29.5 m}^{-1}\text{) for } 2^{7}/_8\text{-inch- diameter (73 mm) pile.}$$

$$T = \text{Final installation torque in ft-lbf or N-m.}$$

The lateral capacity of the pile referenced in Section 4.1.1.2 and Table 1 of this report is based on field testing of the 2⁷/₈-inch-diameter (73 mm) helical pile with a single 8-inch-diameter (203 mm) helix plate installed in a firm clay soil at a minimum embedment of 15 feet (4.57 m). For soil conditions other than firm clay, the lateral capacity of the pile must be determined by a registered design professional.

4.1.2 Driven Pile: Structural calculations and drawings, prepared by a registered design professional, must be submitted to the code official for each project, based on accepted engineering principles, as described in IBC Sections 1604.4 and 1808. The design method for steel components is Allowable Strength Design (ASD), described in IBC Section 1602 and AISC 360 Section B3.4. The structural analysis must consider all applicable internal forces (shear, bending moments and torsional moments, if applicable) due to applied loads, structural eccentricity and maximum span(s) between hydraulically driven steel pilings. The minimum embedment depth for various loading conditions must be included based on the most stringent requirements of the following: engineering analysis, allowable capacities noted in this report, site-specific geotechnical investigation report, and site-specific load tests, if applicable. For driven steel foundation systems subject to combined lateral and axial (compression or tension) loads, the allowable strength under combined loads must be determined using the interaction equation prescribed in Chapter H of AISC 360. A soil investigation report in accordance with Section 4.1.1 of this report must be submitted for each project. The soil interaction capacity between the pile and the soil and the soil effects of the driven installation must be determined by a registered design professional. A minimum safety factor of 3 must be applied to the hydraulically driven pile system. The maximum installation force and working capacity of the driven pile system must be determined in accordance with Ram Jack's installation instructions and as recommended by a registered design professional.

4.2 Installation:

The Ram Jack® Foundation Systems must be installed by Ram Jack® Manufacturing LLC certified and trained installers. The Ram Jack® foundation systems must be installed in accordance with this section (Section 4.2) and the manufacturer's installation instructions. For tension application, the helical pile must be installed such that the minimum depth from the ground surface to the uppermost helix is 12D, where D is the diameter of the largest helix. Helical piles used in tieback applications (retaining wall) must be installed with a minimum embedment of 12D (where D is the diameter of the uppermost helical plate), measured below the ground surface and behind the angle of repose or the active soil wedge, which is the horizontal

distance between the intersection of the tieback and the active sliding surface and the center of the uppermost helical plate, when the retained slope (surface) is vertical. All field-cut or drilled pilings must be protected from corrosion as recommended by the registered design professional.

4.2.1 Hydraulically Driven Steel Piling/Pier Installation:

1. An area must be excavated immediately adjacent to the building foundation to expose the footing, bottom of grade beam, stem wall or column to a width of at least 24 inches (610 mm) and at least 12 inches (305 mm) below the bottom of the footing or grade beam.
2. The vertical and bottom faces of the foundation must, to the extent possible, be smooth and at right angles of each other for the mounting of the pile bracket. The surfaces in contact with the support bracket must be free of all dirt, debris and loose concrete so as to provide firm bearing surfaces. Reference Figure 3 for proper bracket placement.
3. The spread footing, if applicable, must be notched to allow the support bracket seat to mount directly under the bearing load of the stem or basement wall.
4. The pile lead section, guide sleeve and first pile section must be inserted through the bracket sleeve. The double action hydraulic rams must be connected to the support bracket. The pile should not be more than 1 degree from vertical. Hydraulic rams used to install the pile must have the capability of exerting a minimum installation force of 60,000 lbs (267 kN).
5. The hydraulic rams must be reciprocated up and down, with the pile being advanced with each downward stroke. Pile sections must be continuously added as required to advance the pile through unstable soils as required. Advancement of the pile will continue until one of the following occurs: the structure begins to experience uplift flexure as the pile is being advanced, the desired hydraulic pressure is achieved or as determined by the foundation investigation. All piles must be installed individually utilizing the maximum resistance of the structure as a reaction force to install each pile. The location of the driven pile system must be determined by a registered design professional. Lifting of the structure must be verified by the registered design professional to ensure that the foundation and/or superstructure are not overstressed.
6. After piling termination, the excess piling must be cut off at a sufficient height to allow for foundation lifting. The support strap assembly must be installed, and the lifting tool is placed on the head of the pile.
7. The excavation must be back-filled and the soil properly compacted. Excess soil must be removed.

4.2.2 Helical Pile Installation:

1. An area must be excavated immediately adjacent to the building foundation to expose the footing, bottom of grade beam, stem wall or column to a width of at least 24 inches and at least 12 inches below the bottom of the footing or grade beam.
2. The vertical and bottom faces of the footing or grade beam must, to the extent possible, be smooth and at right angles of each other for the mounting of the support bracket. The surfaces in contact with the support bracket must be free of all dirt, debris and loose concrete so as to provide firm bearing surfaces.

3. The spread footing or grade beam, if applicable, must be notched to allow the support bracket seat to mount directly under the bearing load of the stem or basement wall.
4. A hydraulic torque driver head is used to install the helical pile. A helical lead section which has helical plates attached is installed first. The helical lead section must be pinned to the rotary torque driver and advanced into the ground by rotating the helical pile. Additional extension shafts must be added as required to advance the pile through unstable soils as required to bear in a load-bearing stratum. The support bracket can be placed on the pile after the lead section and any extensions with helical plates have been embedded into the soil. The remaining pile extensions can be installed through the bracket sleeve.
5. Advancement of the pile will continue until the minimum installation torque is achieved as specified by the torque correlation method to support the allowable design loads of the structure using a torque factor (K_t) of 9 ft^{-1} (29.5 m^{-1}) for the $2\frac{7}{8}$ -inch-diameter (73 mm) pile. The installation torque must not exceed 7,000 ft-lb (9495 m-N)
6. After piling termination, the excess piling must be cut off at a sufficient height to allow for foundation lifting. If the support bracket has not already been installed, it should be installed now. The support strap assembly must be installed on the support bracket, and the lifting tool placed on the head of the pile.
7. Lifting of the structure or proof loading of the pile can be performed using the hydraulic rams. Lifting of the structure must be verified by the registered design professional to ensure that the foundation and/or superstructure are not overstressed.
8. Once the foundation has been raised and/or stabilized, the nuts on the support strap assembly must be tightened to secure the support strap and bracket to the pile. The lifting tool and hydraulics must then be removed.
9. The excavation must be back-filled and the soil properly compacted. Excess soil and any debris must be removed.

4.2.3 Floor Slab Bracket Helical Pile Installation:

1. A maximum 10-inch-diameter (254 mm) hole through the concrete floor slab must be core drilled and an area below the floor slab must be excavated to allow placement of the floor slab bracket.
2. A helical lead section must be inserted into the floor opening and pin-connected to the rotary torque driver. The pile must then be driven into the ground by rotating the helical pile. Additional extension shafts must be added as required to advance the pile through unstable soils as required to bear in a load-bearing stratum. The support bracket can be placed on the pile after the lead section and any extensions with helical plates have been embedded into the soil. The remaining pile extensions can be installed through the bracket sleeve or the bracket can be placed on the pile after the pile installation is terminated.
3. Advancement of the pile continues until the minimum installation torque is achieved as specified by the torque correlation method to support the allowable design loads of the structure using a torque factor (K_t)

of 9 ft⁻¹ (29.5 m⁻¹) for the 2 7/8-inch-diameter (73 mm) pile. The installation torque must not exceed 7,000 ft-lb (9495 m-N).

4. After piling termination, the excess piling must be cut off at a sufficient height to allow for foundation lifting. If the support bracket has not already been installed, it should be installed now. The support strap assembly must be installed on the support bracket, and the lifting tool placed on the head of the pile. Lifting of the structure must be verified by the registered design professional to ensure that the foundation and/or superstructure are not overstressed.
5. Lifting of the structure or proof loading of the pile may be performed using a hydraulic ram or as otherwise approved by the registered design professional and the code official.
6. Once the floor slab has been raised and/or stabilized, the nuts on the support strap assembly must be tightened to secure the support strap and bracket to the pile. The lifting tool and hydraulic ram must then be removed.
7. The excavation must be back-filled and the concrete replaced in accordance with the registered design professional specifications. Excess soil and any debris must be removed.

4.2.4 New Construction Helical Pile Installation:

1. The lead helical section must be installed and successive extensions must be added as needed until the desired torque and capacity are achieved.
2. The pile must be cut to the desired height upon termination of the pile.
3. The new construction bracket is placed over the top of the pile. If the pile is to be used to resist tension forces, the new construction bracket must be embedded the proper distance into the footing or grade beam as required to resist the tension loads as determined by a registered design professional, and must be through-bolted to the pile. Reference Table 4B for the proper embedment of the pile into the footing or grade beam for tension resistance.
4. Steel reinforcement bars are placed and tied to the bracket if applicable. The concrete is then placed according to the construction documents.

4.3 Special Inspection:

Continuous special inspection in accordance with Section 1704.9 of the IBC is required for installation of the Ram Jack® foundation system. Where on-site welding is required, inspection in accordance with Section 1704.3 of the IBC is required. Inspection must include the following:

1. Verification of product numbers (see Table 1).
2. Types and configurations of helical pier lead sections, pilings, extensions, brackets, bolts and torque.
3. Installation procedures and anticipated piling depth.
4. Required target installation torque of piles and depth of the helical foundation system.
5. Inclination and position of helical piles; hub of pile extension in full contact with bracket; full-surface contact of foundation brackets with concrete; tightness of all bolts; and evidence that the helical pile foundation systems are installed by an approved Ram Jack® installer.

6. Compliance of installation with the approved construction document and this evaluation report.

In lieu of continuous special inspection, periodic special inspection in accordance with IBC Section 1704.9 is permitted provided that all of the following requirements are satisfied: (1) The installers are certified by the manufacturer, and evidence of installer training and certification by the report holder are provided to the code official, (2) Structural observations in accordance with IBC Section 1709 are provided, (3) A periodic inspection schedule, as part of the statement of special inspection, is prepared by the registered design professional, and submitted to and approved by the code official. As a minimum, the periodic inspection schedule must include, but not be limited to, the following:

1. Before the start of work: Verify manufacturer, verify installer's certification by the manufacturer, and confirm helical pile and bracket configuration compliance with the approved construction documents and this evaluation report.
2. Installation of first helical foundation system: Verify that location, installation torque, and depth of the helical pile comply with the approved construction documents and this evaluation report. Verify that installers keep an installation log.
3. First connection to building structure: Verify that installation of brackets complies with the approved construction documents and this evaluation report.
4. End of work: Verify that the installation log complies with requirements specified in the approved construction documents. Also verify that installation of all structural connections complies with approved construction documents and this evaluation report.

5.0 CONDITIONS OF USE

The Ram Jack® Foundation Systems described in this report comply with, or are suitable alternatives to what is specified in, the code indicated in Section 1.0 of this report, subject to the following conditions:

- 5.1 The foundation systems are manufactured, identified and installed in accordance with this report and the manufacturer's published installation instructions. In the event of a conflict between this report and the manufacturer's published installation instructions, the more restrictive governs.
- 5.2 Helical pile and driven pile systems that support structures assigned to Seismic Design Category D, E or F, or are located in Site Class E or F are outside the scope of this report and are subject to the approval of the building official, based upon submission of a design in accordance with the code by a registered design professional.
- 5.3 Installation of the helical pile and hydraulically driven pile systems must be limited to support of uncracked concrete, as determined in accordance with the applicable code.
- 5.4 Both the repair bracket and the new construction bracket must be used only to support structures that are laterally braced as defined in IBC Section 1808.2.5.
- 5.5 The helical pile and hydraulically driven pile systems must not be used in conditions that are indicative of a potential pile corrosion situation as defined by soil resistivity of less than 1000 ohm-cm, a pH of less than 5.5, soils with high organic content, sulfate concentrations greater than 1000 ppm, landfills, or mine waste.

- 5.6 Zinc-coated steel and bare steel components must not be combined in the same system. All helical foundation components must be galvanically isolated from concrete reinforcing steel, building structural steel, or any other metal building components.
- 5.7 The helical piles must be installed vertically into the ground with a maximum allowable angle of inclination of 1 degree.
- 5.8 Special inspection is provided in accordance with Section 4.3 of this report.
- 5.9 Engineering calculations and drawings, in accordance with recognized engineering principles and design parameters, are provided to the building official.
- 5.10 A soils investigation for each project site must be provided to the building official for approval in accordance with Section 4.1.1 of this report.
- 5.11 The minimum helical pile center-to-center spacing is four times and eight times the average helical bearing plate diameters for axial loads and lateral loads, respectively. For piles with closer spacing, the pile allowable load reductions due to pile group effects must be included in the geotechnical report, described in Section 4.1.1 of this report, and must be considered

in the pile design by a registered design professional, and is subject to the approval of the code official.

5.12 The interaction between the hydraulically driven pile system and the soil are outside the scope of this report.

5.13 The Ram Jack® Foundation Systems are manufactured at the Ram Jack Manufacturing, LLC, facility located in Ada, Oklahoma, under a quality control program with inspections by Lenard Gabert & Associates. (AA-640).

6.0 EVIDENCE SUBMITTED

Data in accordance with the ICC-ES Acceptance Criteria for Helical Foundation Systems and Devices (AC358), dated June 2007.

7.0 IDENTIFICATION

The Ram Jack® Foundation System components are identified by a tag or label bearing the Ram Jack logo, the name and address of Gregory Enterprises, Inc., the catalog number, the product description, the evaluation report number (ESR-1854), and the name of the inspection agency (Lenard Gabert & Associates AA-640).

TABLE 1—FOUNDATION MECHANICAL STRENGTH RATINGS OF BRACKETS³

PRODUCT NUMBER	DESCRIPTION	PILING DIAMETER (inches)	ALLOWABLE CAPACITY (kips)		
			Compression	Tension	Lateral
4021.1	Side load bracket	2 ⁷ / ₈	31.50 ⁽¹⁾	N/A	N/A
4038.1	Side load bracket	2 ⁷ / ₈	19.70 ⁽¹⁾	N/A	N/A
4039.1	Side load bracket	2 ⁷ / ₈	31.50 ⁽¹⁾	N/A	N/A
4075.1	New construction	2 ⁷ / ₈	18.20	See Table 2	1.49 ⁽²⁾
4079.1	New construction	2 ⁷ / ₈	33.73	See Table 2	1.49 ⁽²⁾
4093.1	Slab bracket	2 ⁷ / ₈	See Table 3	N/A	N/A
4550.2875.1	Tieback assembly	2 ⁷ / ₈	27.9 @ 20° angle (tension only)		
			27.6 @ 30° angle (tension only)		

For SI: 1 inch = 25.4 mm, 1 kip (1000 lbf) = 4.48 kN.

¹Load capacity is based on full scale load tests per AC358 with an installed 5'-0 unbraced pile length having a maximum of one coupling per IBC 1808.2.9.2. Side load bracket must be concentrically loaded.

²Lateral load capacity is based on lateral load tests performed in firm clay soil per Section 4.1.1 of this report. For any other soil condition, the lateral capacity of the pile must be determined by a registered design professional.

³The capacities listed in Table 1 assume the structure is sidesway braced.

N/A- not applicable.

TABLE 2—ALLOWABLE TENSILE CAPACITY OF THE 4075 & 4079 NEW CONSTRUCTION BRACKET¹

Minimum Required Beam Size (inches)		Concrete Strength	Embedment Depth of Bracket Bearing Plate (inches) ²	Allowable Tensile Capacity (kips)	
Width	Depth			4075.1	4079.1
12	12	2500 psi	8	18.2	-
		3000 psi	8	18.2	-
12	14	2500 psi	10	-	25.3 ⁽³⁾ 33.7 ⁽⁴⁾
	12	3000 psi	9	-	25.3 ⁽³⁾ 33.7 ⁽⁴⁾

For SI: 1 inch= 25.4 mm; 1 kip (1000 lbf)= 4.48 kN; 1 psi= 6.89 kPa.

¹Table 2 provides the allowable tensile capacity and the minimum required beam size to develop the maximum tensile capacity of the 4075 & 4079 new construction bracket. Allowable load capacities have been determined assuming that minimum reinforcement has been provided as specified in Section 10.5.1 of ACI 318-05.

²Embedment depth must be measured from the bottom of the concrete beam to the top of the bracket plate.

³Load capacity achieved using single bolt connection between the bracket sleeve and helical shaft.

⁴Load capacity achieved using double bolt connection between the bracket sleeve and helical shaft.

TABLE 3—MECHANICAL PROPERTIES OF 2.875 INCH DIAMETER HELICAL SHAFT

Mechanical Properties	After Corrosion Loss
Steel Yield Strength, F_y	65 ksi
Steel Ultimate Strength, F_u	80 ksi
Modulus of Elasticity, E	29,000 ksi
Nominal Wall Thickness	0.217 in.
Design Wall Thickness	0.1758 in. (0.026 in. loss for powder as per AC 358 3.9)
Outside Diameter	2.8490 in.
Inside Diameter	2.4974 in.
Cross Sectional Area	1.48 in ²
Moment of Inertia, I	1.32 in ⁴
Radius of Gyration, r	0.95 in.
Section Modulus, S	0.93 in ³
Plastic Section Modulus, Z	1.26 in ³

For **SI**: 1 inch= 25.4 mm; 1 ksi= 6.89 MPa, 1 ft-lbf=1.36 N-m; 1 lbf=4.45 N

TABLE 4A—ALLOWABLE LOAD CAPACITIES IN COMPRESSION FOR THE NEW CONSTRUCTION BRACKET

Bracket Number	Concrete Compressive Strength, psi	Overall Beam Depth, in.	Bracket Embedment Depth, (in)	Allowable Load Capacity of Minimally Reinforced Concrete ⁽¹⁾ , (kips)
4075.1	2500	12	4	18.2 ⁽²⁾
	3000	14	4	18.2 ⁽²⁾
4079.1	2500	12	4	31.06 ⁽³⁾
	3000	14	4	33.73 ⁽³⁾

For **SI**: 1 inch= 25.4 mm; 1 kip (1000 lbf)= 4.48 kN; 1 psi= 6.89 kPa.

⁽¹⁾ The allowable load capacities have been determined assuming that minimum reinforcement has been provided as specified by ACI 318 Section 10.5.1. Embedment depth is measured from the top of the concrete beam to the top of the bracket plate.

⁽²⁾ The allowable capacity of the bracket is limited by the bearing capacity of the bracket bearing plate.

⁽³⁾ The allowable capacity of the bracket is limited by the weld strength between the bracket bearing plate and the bracket sleeve.

TABLE 4B—ALLOWABLE LOAD CAPACITIES IN TENSION FOR THE NEW CONSTRUCTION BRACKET

Bracket Number	Concrete Strength	Beam Depth, (in)	Embedment Depth of Bearing Plate, (in)	Effective Depth, (in)	Allowable Load Capacity for Minimally Reinforced Concrete ^{(1),(2)} , (kips)
4075.1	2500 psi	12	5	1.75	5.25 ⁽³⁾
		12	7	3.75	15.29 ⁽³⁾
		12	9	5.75	18.20 ⁽⁴⁾
	3000 psi	12	5	0.75	5.75 ⁽³⁾
		12	7	2.75	16.75 ⁽³⁾
		12	9	4.75	18.20 ⁽⁴⁾
4079.1	2500 psi	12	5	1.75	5.99 ⁽³⁾
		12	7	3.75	18.47 ⁽³⁾
		12	9	5.75	31.06 ^{(3),(6)}
		14	6	2.75	12.15 ⁽³⁾
		14	8	4.75	24.66 ⁽³⁾
		14	9	5.75	31.06 ^{(3),(6)}
		14	10	6.75	33.73 ^{(5),(6)}
	3000 psi	12	5	1.75	6.56 ⁽³⁾
		12	7	3.75	20.23 ⁽³⁾
		12	9	5.75	33.73 ^{(5),(6)}

For **SI**: 1 inch= 25.4 mm; 1 kip (1000 lbf)= 4.48 kN; 1 psi= 6.89 kPa.

⁽¹⁾ The load capacities have been determined based on a 12" wide grade beam. Effective depth is defined as the distance between the embedment depth of the bearing plate subtracted from the reinforcement cover depth.

⁽²⁾ The grade beam is assumed to be minimally reinforced as required by ACI 318 Section 10.5.1

⁽³⁾ The allowable load capacity is limited by the punching shear capacity of the grade beam

⁽⁴⁾ The allowable load capacity is limited by the bearing capacity of the bracket bearing plate

⁽⁵⁾ The allowable load capacity is limited by the weld strength between the bearing plate and bracket sleeve

⁽⁶⁾ Load capacity achieved using double bolt connection between the bracket sleeve and helical shaft

TABLE 5—ALLOWABLE COMPRESSION CAPACITY of 2 7/8" DIAMETER PILE WITH COUPLER ECCENTRICITY ⁽³⁾ (kips)

	Fully Braced (L _u =0)	kL _u =4 ft ⁽¹⁾	kL _u =8 ft ⁽¹⁾
0 couplings (no eccentricity)	57.47	45.02	21.60
1 coupling ⁽²⁾	57.47	28.68	18.38
2 coupling ⁽²⁾	57.47	N/A	11.81

For **SI**: 1 inch= 25.4 mm; 1 ft= 0.305 m; 1 kip (1000 lbf)= 4.48 kN.

⁽¹⁾ L_u=unbraced length per IBC Section 1808.2.9.2

⁽²⁾ Number of couplings within L_u

⁽³⁾ The capacities shown in Table 5 are for 2 7/8-inch diameter pilings installed with a maximum 1 degree of inclination and do not require the installation of an external guide sleeve. The capacities are also based on the assumption that there is no eccentricity created by the bracket.

TABLE 6—ALLOWABLE COMPRESSIVE LOAD CAPACITY RATING OF RAM JACK'S # 4093 SLAB BRACKET SUPPORTING MINIMALLY REINFORCED NORMAL WEIGHT CONCRETE SLAB^{1,2} (Max. load rating = 11.7 kips)

Concrete Compressive Strength, f'c (psi)	Concrete Floor Slab Depth (t) (in)	Minimum Area of steel reinforcement in Concrete Slab ¹ , A _{s,min} (in ²)	Live Load (psf)	Maximum Pile Spacing		Pile Load (kip)	
				1 & 2 Span	3 Span	1 & 2 Span	3 Span
2,500	4 ⁴	0.06	40	4'-10"	5'-5"	2.12 k	2.65 k
			50	4'-6"	5'-1"	2.08 k	2.60 k
			100	3'-7"	4'-0"	1.99 k	2.49 k
	5 ⁴	0.075	40	5'-8"	6'-4"	3.36 k	4.20 k
			50	5'-5"	6'-0"	3.31 k	4.14 k
			100	4'-4"	4'-11"	3.15 k	3.94 k
	6	0.09	40	6'-6"	7'-3"	4.90 k	6.13 k
			50	6'-2"	6'-11"	4.83 k	6.03 k
			100	5'-1"	5'-8"	4.59 k	5.74 k
	8 ³	0.12	40	8'-8"	9'-1"	10.61 k	11.70 k
			50	8'-3"	8'-9"	10.30 k	11.70 k
			100	6'-9"	7'-7"	9.34 k	11.67 k
3,000	4 ⁴	0.066	40	5'-1"	5'-8"	2.33 k	2.91 k
			50	4'-9"	5'-4"	2.29 k	2.86 k
			100	3'-9"	4'-3"	2.19 k	2.73 k
	5 ⁴	0.082	40	6'-0"	6'-8"	3.69 k	4.62 k
			50	5'-8"	6'-4"	3.64 k	4.54 k
			100	4'-7"	5'-2"	3.46 k	4.33 k
	6	0.098	40	6'-10"	7'-7"	5.39 k	6.73 k
			50	6'-6"	7'-3"	5.30 k	6.63 k
			100	5'-4"	6'-0"	5.05 k	6.31 k
	8 ³	0.131	40	9'-1"	9'-2"	11.66 k	11.70 k
			50	8'-8"	8'-9"	11.31 k	11.70 k
			100	7'-1"	7'-7"	10.26 k	11.70 k

For **SI**: 1 inch= 25.4 mm; 1 kip (1000 lbf)= 4.48 kN; 1 psi= 6.89 kPa; 1 psf= 47.88 Pa.

¹The maximum pile spacing shown are for floor slabs constructed of normal weight concrete (150 pcf) with minimum reinforcement (f_y = 60 ksi) per ACI 318 Section 10.5.1.

²The maximum floor slab spans shown assumes the minimum floor slab reinforcement is placed in the center of the slab (t/2). Longer spans can be achieved if the slab reinforcement is proven to be larger and/or placed below the central line of the floor slab. Structural calculations must be submitted for approval by a registered design professional for spans greater than those shown for a reinforced floor slab.

³The maximum load rating of the 4093 slab bracket controls the pile spacing.

⁴The spans and pile loads shown for the 4-inch and 5-inch thick floor slab assumes the floor slab are being placed on a vapor barrier. Per Section 7.7.1 of ACI 318, the minimum concrete cover required is 1 1/2 inches. This table should not be used for the 4-inch and 5-inch thick floor slabs placed directly on soil, where the minimum concrete cover is 3 inches, which places the reinforcement above the neutral axis. Table 7 should be used for the 4 inch and 5 inch thick concrete slab cast directly on soil.

TABLE 7—ALLOWABLE COMPRESSIVE LOAD CAPACITY RATING OF RAM JACK'S # 4093 SLAB BRACKET SUPPORTING STRUCTURAL PLAIN CONCRETE SLAB^{1,2}
(Max. load rating = 11.7 kips)

Concrete Compressive Strength, f'c (psi)	Concrete Floor Slab Depth (t) (in)	Effective Floor Slab Depth ² , (t-2) (in)	Live Load (psf)	Maximum Pile Spacing		Pile Load (kip)	
				1 & 2 Span	3 Span	1 & 2 Span	3 Span
2,500	4	2	40	2'-5"	2'-8"	0.54 k	0.68 k
			50	2'-3"	2'-6"	0.53 k	0.67 k
			100	1'-10"	2'-0"	0.51 k	0.63 k
	5	3	40	3'-8"	4'-1"	1.22 k	1.53 k
			50	3'-5"	3'-10"	1.20 k	1.50 k
			100	2'-9"	3'-0"	1.14 k	1.42 k
	6	4	40	4'-10"	5'-5"	2.17 k	2.71 k
			50	4'-7"	5'-1"	2.13 k	2.66 k
			100	3'-8"	4'-1"	2.02 k	2.53 k
	8 ³	6	40	7'-4"	8'-2"	4.88 k	6.11 k
			50	6'-11"	7'-8"	4.8 k	6.00 k
			100	5'-6"	6'-1"	4.55 k	5.69 k
3,000	4	2	40	2'-6"	2'-10"	0.59 k	0.74 k
			50	2'-4"	2'-8"	0.58 k	0.73 k
			100	1'-11"	2'-1"	0.55 k	0.69 k
	5	3	40	3'-10"	4'-3"	1.34 k	1.67 k
			50	3'-7"	4'-0"	1.31 k	1.64 k
			100	2'-10"	3'-2"	1.25 k	1.56 k
	6	4	40	5'-1"	5'-8"	2.38 k	2.97 k
			50	4'-9"	5'-4"	2.34 k	2.92 k
			100	3'-10"	4'-3"	2.22 k	2.77 k
	8 ³	6	40	7'-8"	8'-7"	5.35 k	6.69 k
			50	7'-2"	8'-1"	5.25 k	6.57 k
			100	5'-9"	6'-5"	4.98 k	6.23 k

For SI: 1 inch= 25.4 mm; 1 kip (1000 lbf)= 4.48 kN; 1 psi= 6.89 kPa; 1 psf= 47.88 Pa.

¹The maximum pile spacing shown are for floor slabs constructed of normal weight concrete (145 pcf) with no reinforcement

²As per ACI 318 the overall thickness of the concrete footings cast directly on the soil surface has to be reduced by 2 inches to account for the unevenness of excavation and contamination of the concrete cast. The maximum pile spacing and pile loads presented in Table 7 (above) have been computed assuming that the slabs have been cast directly onto the soil without the use of vapor barriers and/or cast on soils that have been unevenly prepared, consequently resulting in reduction of overall slab thickness by 2 inches, as indicated in Section 22.4.8 of ACI 318.

³The maximum allowable load capacity of the bracket controls the pile spacing.

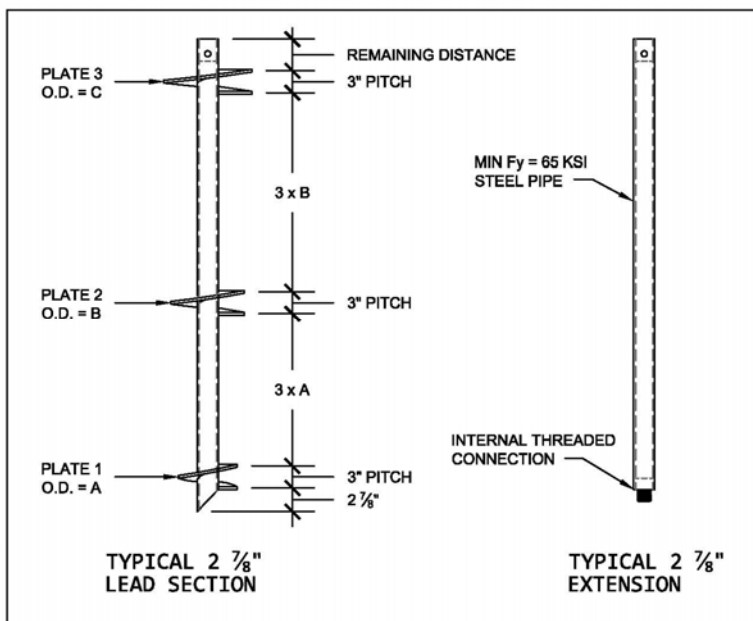

FIGURE 1—TYPICAL HELICAL PILE AND PLATE SPACING CHARACTERISTICS

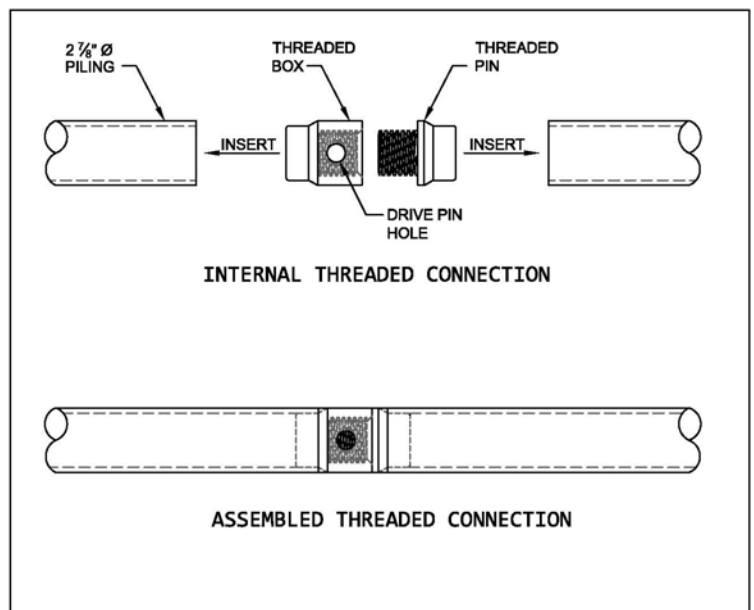

FIGURE 2—TYPICAL HELICAL PILE SYSTEM INTERNAL THREADED CONNECTION DETAIL FOR 2 7/8\"/>

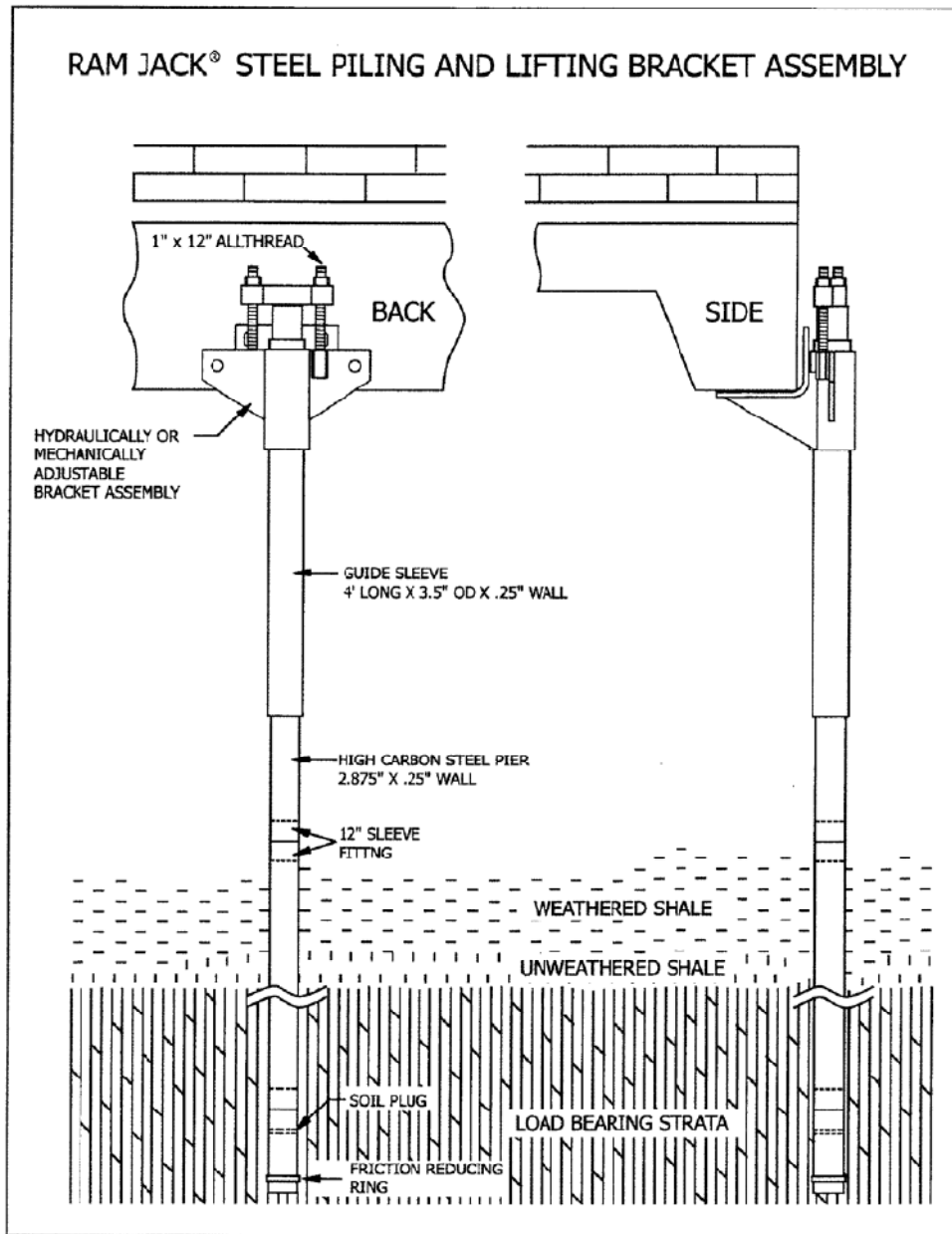

FIGURE 3—TYPICAL DRIVEN PILING USED IN CONJUNCTION WITH THE COMMERCIAL BRACKET #4021

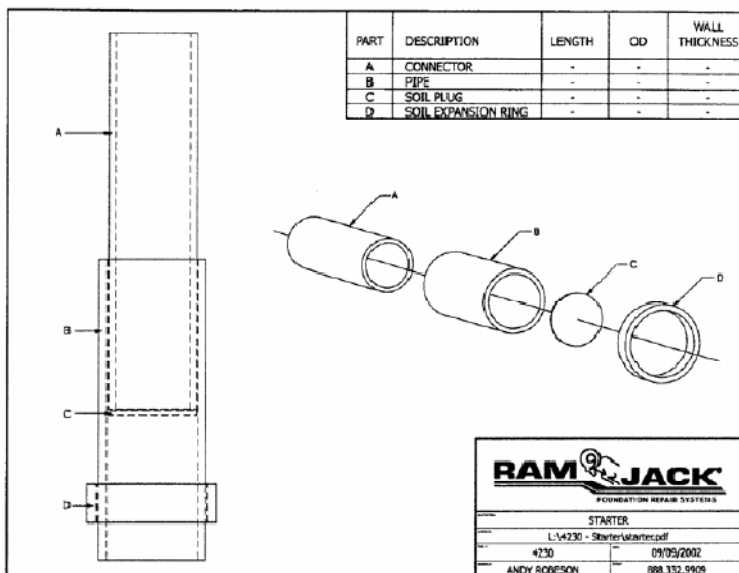

FIGURE 4—DETAIL OF STARTER JOINT

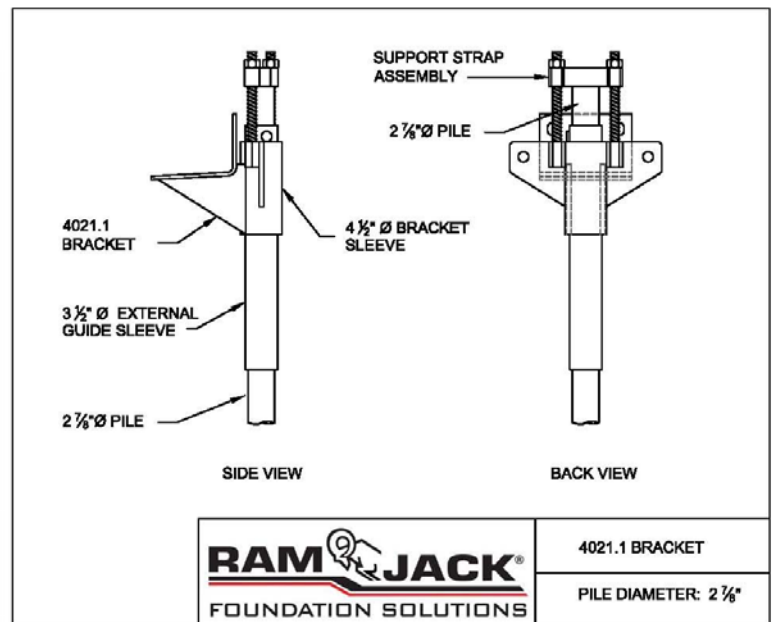

FIGURE 5—4021.1 SUPPORT BRACKET ASSEMBLY WITH GUIDE SLEEVE AND PILING

RAM JACK
FOUNDATION SOLUTIONS

4021.1 BRACKET
PILE DIAMETER: 2 1/8"

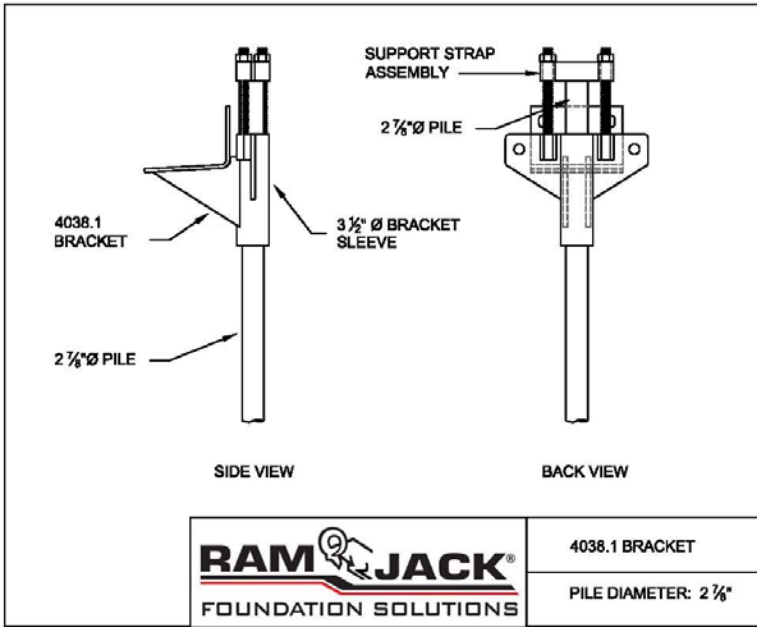

FIGURE 6—4038.1 SUPPORT BRACKET AND PILING

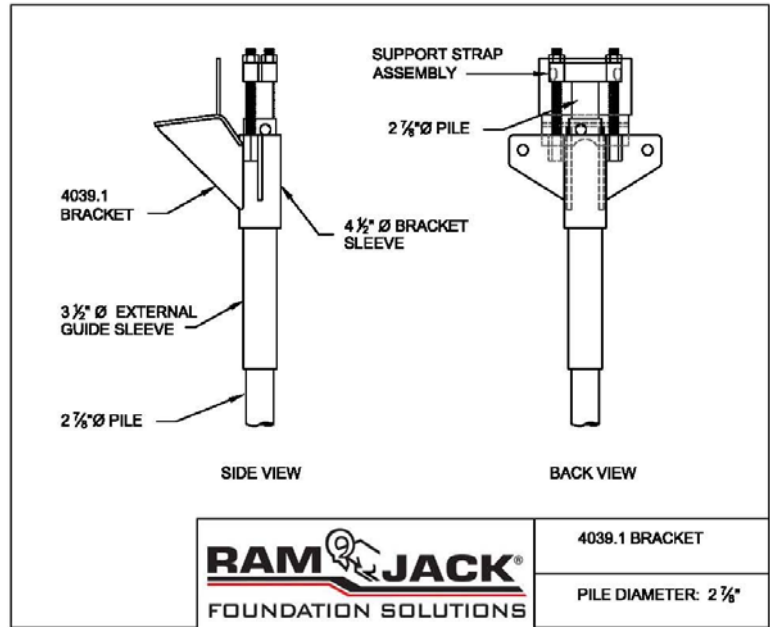

FIGURE 7—4039.1 SUPPORT BRACKET AND PILING

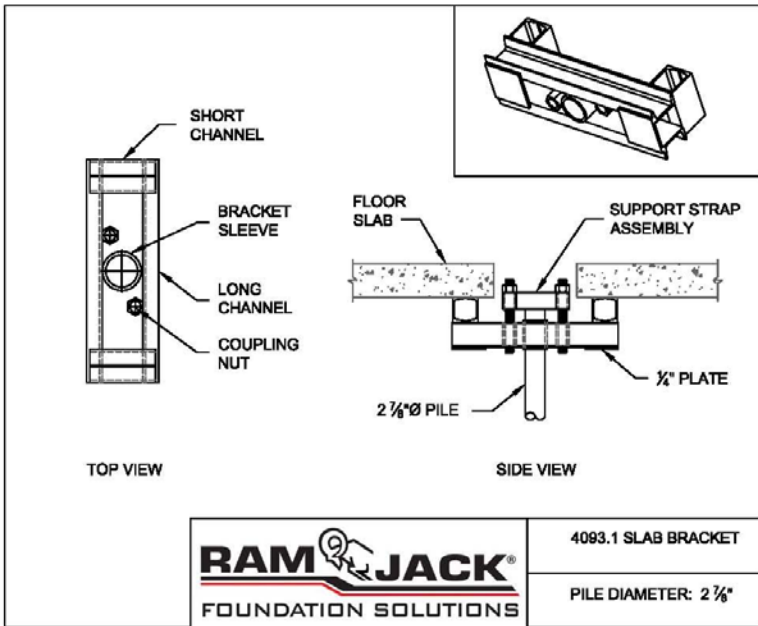

FIGURE 8—4093.1 FLOOR SLAB BRACKET AND PILING

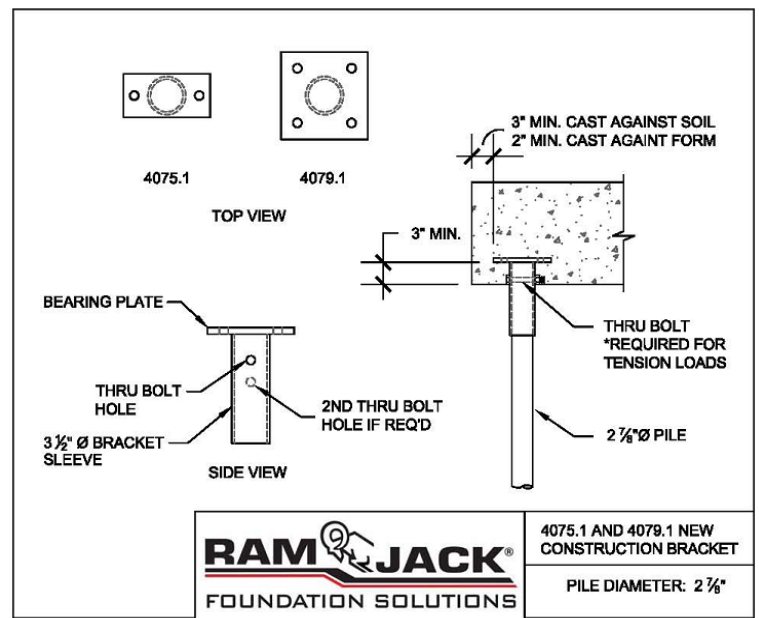

FIGURE 9—4075.1 AND 4079.1 NEW CONSTRUCTION BRACKETS

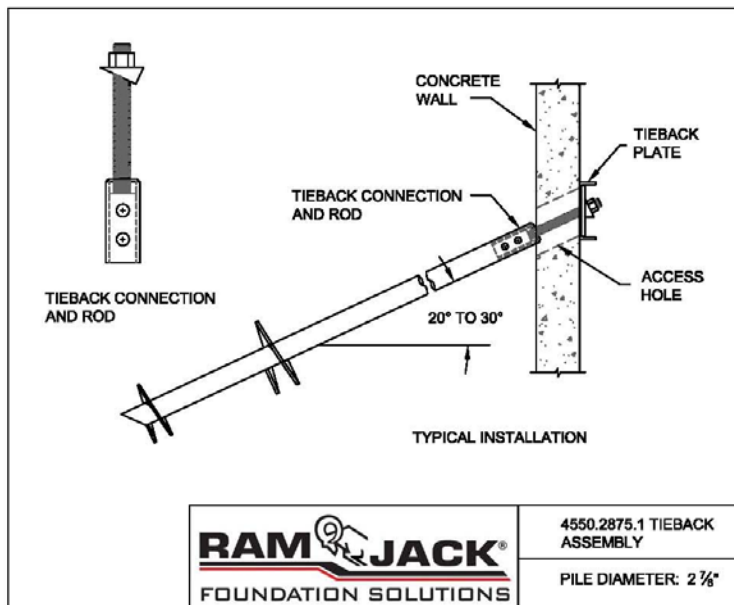

FIGURE 10—4550.2875.1 TIEBACK ASSEMBLY