

ICC-ES Evaluation Report**ESR-1854***

Reissued December 1, 2012

This report is subject to renewal February 1, 2015.

www.icc-es.org | (800) 423-6587 | (562) 699-0543

A Subsidiary of the International Code Council®

DIVISION: 31 00 00—EARTHWORK
Section: 31 63 00—Bored Piles**REPORT HOLDER:****GREGORY ENTERPRISES, INC.**
13655 COUNTY ROAD 1570
ADA, OKLAHOMA 74820
(580) 332-9980
www.ramjack.com
steve@ramjack.com**ADDITIONAL LISTEE:****RAM JACK MANUFACTURING, LLC**
13655 COUNTY ROAD 1570
ADA, OKLAHOMA 74820**EVALUATION SUBJECT:****RAM JACK® FOUNDATION SYSTEMS****1.0 EVALUATION SCOPE****Compliance with the following codes:**2012, 2009 and 2006 *International Building Code* (IBC)**Properties evaluated:**

Structural and geotechnical

2.0 USES

Ram Jack® Foundation Systems include a helical pile system and a hydraulically driven steel piling system. The helical pile system is used to transfer compressive, tension, and lateral loads from a new or existing structure to soil bearing strata suitable for the applied loads. The hydraulically driven steel piling system is used to transfer compressive loads from existing foundations to load-bearing soil strata that are adequate to support the downward-applied compression loads. Brackets are used to transfer the loads from the building foundation to the helical pile system or the hydraulically driven steel piling system.

3.0 DESCRIPTION**3.1 General:**

The Ram Jack® Foundation Systems consist of either helical piles or hydraulically driven steel pilings connected to brackets that are in contact and connected with the load-bearing foundation of a structure.

3.2 System Components:

3.2.1 Helical Pile System—Lead Shafts with Helical Plates and Extensions: The lead shafts consist of either 2⁷/₈- or 3¹/₂-inch-outside-diameter (73 or 89 mm) steel pipe having a nominal shaft thickness of 0.217 or 0.254 inch, respectively. Helical-shaped discs, welded to the pipe, advance the helical piles into the soil when the pile is rotated. The helical discs (plates) are 8, 10, 12 or 14 inches (203, 254, 305 or 356 mm) in diameter, and are cut from 3³/₈-inch- or 1¹/₂-inch-thick (9.5 or 12.7 mm) steel plate. The helical plates are pressed, using a hydraulic press and die, to achieve a 3-inch (76 mm) pitch, and are then shop-welded to the helical lead shaft. Figure 1 illustrates a typical helical pile. The extensions have shafts similar to the lead sections, except without the helical plates. The helical pile lead sections and extensions are connected together by using an internal threaded pin and box system that consists of a box shop-welded into the trailing end of the helical lead or extension sections. Each extension consists of a threaded pin and box on opposing ends. Figure 2 illustrates the helical pin and box connections. The lead shafts and extensions are coated with a polyethylene copolymer coating complying with the ICC-ES Acceptance Criteria for Corrosion Protection of Steel Foundation Systems Using Polymer (EAA) Coatings (AC228), and having a minimum coating thickness of 18 mils (0.46 mm) as described in the approved quality documentation.

3.2.2 Hydraulically Driven Pile System—Pilings, Connectors, Starter, and Guide Sleeve: The pilings consist of 2⁷/₈-inch-outside-diameter (73 mm) pipe having a nominal shaft thickness of 0.217 inch, in either 3-, 5- or 7-foot-long (914, 1524, or 2134 mm) sections. Connectors used to connect the pilings together are 12-inch-long (305 mm), 2³/₈-inch-outside-diameter (60.3 mm) pipe having a nominal shaft thickness of 0.19 inch, shop crimped and inserted in one end of the piling section so that approximately 6 inches of the connector extends out of one end of the piling section. During installation, the subsequent piling section slides over the connector of the previous piling section. Figure 3 illustrates a typical piling used in conjunction with a bracket. The starter consists of a 2⁷/₈-inch-diameter (73 mm) steel pipe having a nominal shaft thickness of 0.217 inch, and a 2³/₈-inch-outside-diameter (60.3 mm) pipe having a nominal shaft thickness of 0.19-inch, which is shop crimped and inserted in one end of the piling section so that approximately 6 inches of the connector extends out of one end of the piling section. A 2³/₈-inch-diameter-by-1¹/₈-inch-thick (3.2 mm by 60.3 mm) ASTM A36 steel soil plug is shop-welded inside the 2⁷/₈-inch (73 mm) starter section against the 2³/₈-inch (60.3 mm) connector. The starter section is jobsite-installed into the end of the initial piling and leads the piling

*Revised July 2013

in order to expand the soil away from the piling with a 3¹/₂-inch-outside-diameter (89 mm) steel ring having a nominal wall thickness of 0.254 inch, shop-welded to the starter section 1 inch (25.4 mm) from the bottom edge to reduce skin friction. Figure 4 illustrates a typical starter joint. A steel pipe guide sleeve, shown in Figure 3, is used to laterally strengthen the driven pile. The starter, guide sleeve, and pilings are coated with polymer coating complying with AC228 and having a minimum coating thickness of 18 mils (0.46 mm), as described in the approved quality documentation.

3.2.3 Brackets: Brackets are constructed from steel plate and steel pipe components, which are factory-welded together. The different brackets are described in Sections 3.2.3.1 through 3.2.3.7. All brackets are coated with polymer coating complying with AC228 and having a minimum thickness of 18 mils (0.46 mm), as described in the approved quality documentation.

3.2.3.1 Support Bracket #4021.1: This bracket is used to support existing concrete foundations supporting axial compressive loading. The bracket is constructed of a ³/₈-inch-thick (9.5 mm) steel plate bent to a 90-degree angle seat measuring 10 inches (254 mm) wide by 9 inches (229 mm) long on the horizontal leg and 7 inches (178 mm) on the vertical leg. The seat is factory-welded to a 4¹/₂-inch-outside-diameter (114 mm) steel bracket sleeve having a nominal wall thickness of 0.438 inch. The external guide sleeve, a 3¹/₂-inch-outside-diameter (89 mm) steel pipe having a nominal wall thickness of 0.254 inch, is inserted through the bracket sleeve. The 2⁷/₈-inch-outside-diameter (73 mm) pile is inserted through the external guide sleeve. Once the 2⁷/₈-inch-outside-diameter (73 mm) pile shaft has been installed through the external guide sleeve, the pile is cut approximately 6 inches above the bracket. Two 1-inch-diameter (25 mm) all-thread bolts are installed into the matching nuts which are factory-welded to each side of the bracket sleeve. A ³/₄-inch-thick (19 mm) support strap measuring 5 inches (127 mm) long by 2 inches (51 mm) in width is then placed over the all-thread bolts and centered on top of the pile. The support strap is then attached to the bracket with two 1-inch (25 mm) hex nuts screwed down on the all-threads. This bracket can be used with both the helical and driven pile systems. Figure 5 shows additional details.

3.2.3.2 Support Bracket #4021.55: The bracket is similar to the 4021.1 bracket but is designed to support larger axial compressive loads from existing structures. The bracket is constructed of a ³/₈-inch-thick (9.5 mm) steel plate bent to a 90-degree angle seat measuring 10 inches (254 mm) wide by 9 inches (229 mm) long on the horizontal leg and 7 inches (178 mm) on the vertical leg. The seat is factory-welded to a 5¹/₂-inch-outside-diameter (140 mm) steel bracket sleeve having a nominal wall thickness of 0.375 inch. The external sleeve, a 4¹/₂-inch-outside-diameter (114 mm) steel pipe having a nominal wall thickness of 0.438 inch, is inserted through the bracket sleeve. A 3¹/₂-inch-outside-diameter (89 mm) pile is inserted through the external guide sleeve. Once the 3¹/₂-inch-outside-diameter (89 mm) pile shaft has been installed through the external guide sleeve, the pile is cut approximately 6 inches (152 mm) above the bracket. Two 1¹/₄-inch-diameter (32 mm) all-thread bolts are installed into the matching hex nuts which are shop-welded to each side of the bracket sleeve. A 2¹/₄-inch-square-bar support strap is then placed over the all-thread bolts and centered on top of the pile. The support strap is then attached to the bracket with two 1¹/₄-inch (32 mm) hex nuts screwed down on the all-threads. Figure 5 shows additional details.

3.2.3.3 Support Bracket #4038.1: This bracket is similar to the 4021.1 bracket but is designed for lighter loads and is only used with the helical pile system on existing structures to support axial compressive loads. The bracket is constructed of a ³/₈-inch-thick (9.5 mm) steel plate bent to a 90-degree angle seat measuring 10 inches wide (254 mm) by 9 inches (229 mm) long on the horizontal leg and 7 inches (178 mm) long on the vertical leg. The seat is welded to a 3¹/₂-inch-outside-diameter (89 mm) steel bracket sleeve. The 2⁷/₈-inch-outside-diameter (73 mm) pile is inserted through the bracket sleeve. Once the 2⁷/₈-inch-outside-diameter (73 mm) pile has been installed, the pile is cut approximately 6 inches above the bracket. Two 1-inch-diameter (25 mm) all-thread bolts are installed in matching nuts which are factory-welded to each side of the bracket sleeve. A ³/₄-inch-thick (19 mm) support strap is then placed over the all-thread bolts and centered on top of the pile. The support strap is then attached to the bracket with two 1-inch (25 mm) hex nuts screwed down on the all-threads. Figure 6 shows additional details.

3.2.3.4 Support Bracket #4039.1: This is a low-profile bracket used to underpin existing structures to support axial compressive loads where the bottom of the footing is approximately 6 inches to 10 inches below grade. The bracket is constructed of a ³/₈-inch-thick (9.5 mm) steel plate measuring 10 inches (254 mm) wide by 6.75 inches (172 mm) long, factory-welded to a 4¹/₂-inch-outside-diameter (114 mm) steel bracket sleeve. The external guide sleeve, a 3¹/₂-inch-outside-diameter (89 mm) steel pipe, is inserted through the bracket sleeve. The 2⁷/₈-inch-outside-diameter (73 mm) pile is inserted through the external guide sleeve. Once the 2⁷/₈-inch-outside-diameter (73 mm) pile has been installed, the pile is cut approximately 6 inches above the bracket. Two 1-inch-diameter (25 mm) all-thread bolts are installed in matching hex nuts which are factory-welded to each side of the bracket sleeve. A ³/₄-inch-thick (19 mm) support strap is then placed over the all-thread bolts and centered on top of the pile. The support strap is then attached to the bracket with two 1-inch (25 mm) hex nuts screwed down on the all-threads. This bracket can be used with both the helical and driven pile systems. Figure 7 shows additional details.

3.2.3.5 Slab Bracket #4093: This bracket is used to underpin and raise existing concrete floor slabs to support axial compressive loading. The slab bracket consists of two 20-inch-long (508 mm) steel channels (long channels) spaced 3¹/₂ inches (89 mm) apart, with two sets of 6-inch-long (152 mm) channels (short channels) welded flange-to-flange (face-to-face) and then factory-welded to the top side of each end of the long channels. One-quarter-inch-thick-by-4-inch-by-5-inch (6 mm by 102 mm by 127 mm) steel plates are factory-welded on the bottom on each end of the long channels. The bracket sleeve is 3¹/₂-inch-outside-diameter (73 mm) steel tube factory-welded to and centered between the two long channels. Two 1-inch-diameter (25 mm) coupling hex nuts are factory-welded to the long channels on each side of the bracket sleeve. Once the 2⁷/₈-inch-outside-diameter (73 mm) pile has been installed, the pile is cut approximately 6 inches above the bracket. Two 1-inch-diameter (25 mm) all-thread bolts are installed in matching hex nuts which are factory-welded to each side of the bracket sleeve. A ³/₄-inch-thick (19 mm) support strap is then placed over the all-thread bolts and centered on top of the pile. The support strap is then attached to the bracket with two 1-inch (25 mm) hex nuts screwed down on the all-threads. This bracket is only used with the helical pile system. Figure 8 contains additional details.

3.2.3.6 New Construction Brackets #4075.1, #4076.1 and #4079.1:

These brackets are used with the helical pile system in new construction where the steel bearing plate of the bracket is cast into the new concrete grade beam, footing or pile cap concrete foundations. The brackets can transfer compression, tension and lateral loads between the pile and the concrete foundation. The 4075.1 has a $\frac{5}{8}$ -inch-thick-by-4-inch-wide-by-8-inch-long (15.9 mm by 102 by 203 mm) bearing plate with two predrilled holes. The 4076.1 has a 1-inch-thick-by-9-inch-wide-by-9-inch-long (25 mm by 229 mm by 229 mm) bearing plate with four predrilled holes. The 4079.1 has a $\frac{5}{8}$ -inch-thick-by-8-inch-wide-by-8-inch-long (16 mm by 203 by 203 mm) bearing plate with four predrilled holes. The 4075.1 and 4079.1 bracket steel bearing plates are factory-welded to a $3\frac{1}{2}$ -inch-outside-diameter (89 mm) steel sleeve with a predrilled $\frac{13}{16}$ -inch-diameter (20.6 mm) hole. The 4076.1 bracket steel bearing plate is factory-welded to a $2\frac{7}{8}$ -inch-outside-diameter (73 mm) steel sleeve with predrilled $\frac{13}{16}$ -inch-diameter (20.6 mm) holes. The 4075.1 and 4079.1 brackets are used with the $2\frac{7}{8}$ -inch-diameter helical piles. The 4076.1 bracket is used with the 3.5-inch-diameter helical piles. The bracket is embedded into the foundation unit to provide the effective cover depth and to transfer the tensile and compressive forces between steel bearing plate and surrounding concrete. The bracket is attached to the pile shaft with either one or two $\frac{3}{4}$ -inch-diameter (19.1 mm) through-bolts, as shown in Table 3B of this report, to complete the transfer of tension forces to the pile shaft. Figure 9 contains additional details.

3.2.3.7 #4550.2875.1 Tieback Bracket Assembly: This assembly is used with a helical pile and is only designed for tension loads. The assembly consists of two major components, a tieback connection with rod and a tieback plate. The tieback connection is a $2\frac{3}{8}$ -inch-diameter (60 mm) steel sleeve with two predrilled holes to accept through-bolts for the connection to the helical pile pipe. One end of the steel sleeve has a $1\frac{1}{2}$ -inch-diameter (38 mm) hex nut factory-welded to the sleeve to accept a $1\frac{1}{2}$ -inch-diameter (38 mm) all-thread rod that extends through the wall being supported. The tieback plate is an 8-inch-deep (203 mm) channel with a stiffening plate with a $1\frac{7}{8}$ -inch-diameter (48 mm) hole in its center. The assembly is secured with a $1\frac{1}{2}$ -inch-by- $\frac{1}{2}$ -inch (38 by 12.7 mm) wedge washer and nut. Figure 10 shows additional details.

3.3 Material Specifications:

3.3.1 Helix Plates: The carbon steel plates conform to ASTM A36, except they have a minimum yield strength of 50,000 psi (345 MPa) and a minimum tensile strength of 70,000 psi (483 MPa).

3.3.2 Helical Pile Lead Shafts and Extensions: The lead shafts and extensions are carbon steel round tubes that conform to ASTM A500, Grade C, except they have a minimum yield strength of 65,000 psi (448 MPa) and a minimum tensile strength of 80,000 psi (552 MPa).

3.3.3 Piling Sections: The piling sections, connectors, starters and guide sleeves are carbon steel round tube conforming to ASTM A500, Grade C, except they have a minimum yield strength of 65,000 psi (448 MPa) and a minimum tensile strength of 80,000 psi (552 MPa).

3.3.4 Brackets:

3.3.4.1 Plates: The $\frac{3}{8}$ -inch- and $\frac{1}{2}$ -inch-thick (10 and 12.7 mm) steel plates used in the brackets conform to ASTM A36, but have a minimum yield strength of 50,000 psi (345 MPa) and a minimum tensile strength of 70,000 psi (483 MPa). The $\frac{1}{4}$ -inch- and $\frac{5}{8}$ -inch-thick

(6.4 and 15.9 mm) steel plates used in the brackets conform to ASTM A36, having a minimum yield strength of 36,000 psi (248 MPa) and a minimum tensile strength of 60,000 psi (413 MPa).

3.3.4.2 Channels: The steel channel used in the brackets conforms to ASTM A36, having a minimum yield strength of 36,000 psi (248 MPa) and a minimum tensile strength of 60,000 psi (413 MPa).

3.3.5 Sleeves: The carbon steel round tube used in the bracket assembly as a sleeve conforms to ASTM A500, Grade C, except it has a minimum yield strength of 65,000 psi (448 MPa) and a minimum tensile strength of 80,000 psi (552 MPa).

3.3.6 Threaded Rods, Bolts and Nuts:

3.3.6.1 Helical Piles : The threaded pin and box used in connecting the $2\frac{7}{8}$ -inch-diameter (73 mm) helical lead shafts and extensions together conform to ASTM A322, Grade 4140, having a minimum yield strength of 95,000 psi (655 MPa) and a minimum tensile strength of 148,000 psi (1020 MPa). The threaded pin and box used in connecting the $3\frac{1}{2}$ -inch-diameter (89 mm) helical lead shafts and extensions together conform to ASTM A29, Grade 1018, having a minimum yield strength of 32,000 psi (220 MPa) and a minimum tensile strength of 58,000 psi (400 MPa).

3.3.6.2 All Other Fastening Assemblies (Including Brackets): The threaded rods conform to ASTM A307 and ASTM A449. The nuts conform to ASTM A563, Grade DH. The threaded rods and nuts are Class B hot-dipped galvanized in accordance with ASTM A153. Through-bolts used to connect the new construction bracket and tieback bracket assembly to the pile to transfer tension forces conform to ASTM A325 Type I and must be hot-dip galvanized in accordance with ASTM A153.

4.0 DESIGN AND INSTALLATION**4.1 Design:**

4.1.1 Helical Pile: Structural calculations and drawings, prepared by a registered design professional, must be submitted to the code official for each project, based on accepted engineering principles, as described in IBC Section 1604.4 and 2012 and 2009 IBC Section 1810 and 2006 IBC Section 1808, as applicable. The load values (capacities) shown in this report are based on the Allowable Strength Design (ASD) method. The structural analysis must consider all applicable internal forces (shear, bending moments and torsional moments, if applicable) due to applied loads, structural eccentricity and maximum span(s) between helical foundations. The result of the analysis and the structural capacities must be used to select a helical foundation system based on the structural and geotechnical demands. The minimum embedment depth for various loading conditions must be included based on the most stringent requirements of the following: engineering analysis, tested conditions described in this report, site-specific geotechnical investigation report, and site-specific load tests, if applicable. For helical foundation systems subject to combined lateral and axial (compression or tension) loads, the allowable strength of the shaft under combined loads must be determined using the interaction equation prescribed in Chapter H of AISC 360.

A soils investigation report must be submitted to the code official as part of the required submittal documents, prescribed in Section 107 of the 2012 IBC and 2009 IBC (2006 IBC Section 106), at the time of permit application. The geotechnical report must include, but not be limited to, all of the following:

1. A plot showing the location of the soil investigation.
2. A complete record of the soil boring and penetration test logs and soil samples.
3. A record of soil profile.
4. Information on groundwater table, frost depth and corrosion-related parameters, as described in Section 5.5 of this report.
5. Soil properties, including those affecting the design such as support conditions of the piles.
6. Allowable soil bearing pressure.
7. Confirmation of the suitability of helical foundation systems for the specific project.
8. Recommendations for design criteria, including but not be limited to, mitigation of effects of differential settlement and varying soil strength; and effects of adjacent loads.
9. Recommended center-to-center spacing of helical pile foundations, if different from spacing noted in Section 5.11 of this report; and reduction of allowable loads due to the group action, if necessary.
10. Field inspection and reporting procedures (to include procedures for verification of the installed bearing capacity, when required).
11. Load test requirements.
12. Any questionable soil characteristics and special design provisions, as necessary.
13. Expected total and differential settlement.
14. The axial compression, axial tension and lateral load soil capacities if values cannot be determined from this evaluation report.

The allowable axial compressive or tensile load of the helical pile system must be based on the least of the following in accordance with 2012 and 2009 IBC Section 1810.3.3.1.9:

- Sum of the areas of the helical bearing plates times the ultimate bearing capacity of the soil or rock comprising the bearing stratum divided by a safety factor of 2. This capacity will be determined by a registered design professional based on site-specific soil conditions.
- Allowable capacity determined from well-documented correlations with installation torque. Section 4.1.1.4 of this report includes torque correlation factors used to establish pile capacities based on documented correlations.
- Allowable capacity from load tests. This capacity will be determined by a registered design professional for each site-specific condition.
- Allowable axial capacity of pile shaft. Section 4.1.1.2 of this report includes pile shaft capacities.
- Allowable axial capacity of pile shaft couplings. Section 4.1.1.2 of this report includes pile shaft coupling capacities.
- Sum of the allowable axial capacity of helical bearing plates affixed to pile. Section 4.1.1.3 of this report includes helical plate axial capacities.
- Allowable axial capacity of the bracket. Section 4.1.1.1 of this report includes bracket capacities.

4.1.1.1 Bracket Capacity: The concrete foundation must be designed and justified to the satisfaction of the code

official with due consideration to the eccentricity of applied loads, including reactions provided by the brackets, acting on the concrete foundation. Only localized limit states of supporting concrete foundation, including bearing and punching shear, have been evaluated in this evaluation report. Other limit states are outside the scope of this evaluation report and must be determined by the registered design professional. The effects of reduced lateral sliding resistance due to uplift from wind or seismic loads must be considered for each project. Reference Table 1 for the allowable bracket capacity ratings.

4.1.1.2 Pile Shaft Capacity: The top of shafts must be braced as described in 2012 and 2009 IBC Section 1810.2.2, and 2006 IBC Section 1808.2.5. In accordance with 2012 and 2009 IBC Section 1810.2.1, and 2006 IBC Section 1808.2.9, any soil other than fluid soil must be deemed to afford sufficient lateral support to prevent buckling of the systems that are braced, and the unbraced length is defined as the length of piles standing in air, water, or in fluid soils plus an additional 5 feet (1524 mm) when embedded into firm soil or an additional 10 feet (3048 mm) when embedded into soft soil. Firm soils must be defined as any soil with a Standard Penetration Test blow count of five or greater. Soft soils must be defined as any soil with a Standard Penetration Test blow count greater than zero and less than five. Fluid soils must be defined as any soil with a Standard Penetration Test blow count of zero [weight of hammer (WOH) or weight of rods (WOR)]. Standard Penetration Test blow count must be determined in accordance with ASTM D1586. The shaft capacity of the helical foundation systems in air, water, and fluid soils must be determined by a registered design professional. The following are the allowable stress design (ASD) shaft capacities:

- ASD Compression Capacity: Reference Tables 4A and 4B
- ASD Tension Capacity: 57.5 kips (255.8 kN) for 2⁷/₈-inch helical pile; 60 kips (266.9 kN) for 3¹/₂-inch helical pile
- ASD Lateral: 1.49 kips (6.6 kN) for 2⁷/₈-inch helical pile; 2.79 kips (12.4 kN) for 3¹/₂-inch helical pile
- Torque Rating: 8,200 ft-lb (11 110 5 N-m) for 2⁷/₈-inch-diameter helical pile; 14,000 ft-lb (18 67 N-m) for 3¹/₂-inch-diameter helical pile

The elastic shortening/lengthening of the pile shaft will be controlled by the strength and section properties of the 2⁷/₈-inch-diameter (73 mm) or 3¹/₂-inch-diameter (89 mm) piling sections. The elastic deflection of the 2⁷/₈-inch-diameter (73 mm) piling will be limited to 0.010 inch per linear foot of pile (0.83 millimeter per meter) for the allowable (compression or tensile) pile capacity of 36.9 kips (164.1 kN). The elastic deflection of the 3¹/₂-inch-diameter (89 mm) piling will be limited to 0.009 inch per linear foot of pile (0.75 millimeter per meter) for the allowable (compression or tension) pile capacity of 49.0 kips (218 kN). The mechanical properties of the piling sections are shown in Table 2 and can be used to calculate the anticipated settlements due to elastic shortening/lengthening of the pile shaft.

4.1.1.3 Helix Plate Capacity: Up to six helix plates can be placed on a single helical pile. The helix plates are spaced three times the diameter of the lowest plate apart starting at the toe of the lead section. For helical piles with more than one helix, the allowable helix capacity for the helical foundation systems and devices may be taken as the sum of the least allowable capacity of each individual helix. The helix plate ASD capacities are as shown in Table 6.

4.1.1.4 Soil Capacity: The allowable axial compressive or tensile soils capacity must be determined by a registered design professional in accordance with a site-specific geotechnical report, as described in Section 4.1.1, combined with the individual helix bearing method (Method 1), or from field loading tests conducted under the supervision of a registered design professional (Method 2). For either Method 1 or Method 2, the predicted axial load capacities must be confirmed during the site-specific production installation, such that the axial load capacities predicted by the torque correlation method are equal to or greater than what is predicted by Method 1 or 2, described above. The individual bearing method is determined as the sum of the individual areas of the helical bearing plates times the ultimate bearing capacity of the soil or rock comprising the bearing stratum. The design allowable axial load must be determined by dividing the total ultimate axial load capacity predicted by either Method 1 or 2, above, divided by a safety factor of at least 2. The torque correlation method must be used to determine the ultimate capacity (Q_{ult}) of the pile and the minimum installation torque (Equation 1). A factor of safety of 2 must be applied to the ultimate capacity to determine the allowable soil capacity (Q_{all}) of the pile (Equation 2).

$$Q_{ult} = K_t T \quad (\text{Equation 1})$$

$$Q_{all} = 0.5 Q_{ult} \quad (\text{Equation 2})$$

where:

K_t = Torque correlation factor of 9 ft^{-1} (29.5 m^{-1}) for $2\frac{7}{8}$ -inch-diameter (73 mm) pile; or 7 ft^{-1} (22.9 m^{-1}) for $3\frac{1}{2}$ -inch-diameter (89 mm) pile.

T = Final installation torque in ft-lbf or N-m. The final installation torque is defined as the last torque reading taken when terminating the helical pile installation. The torque measurement can be determined using calibrated hydraulic gauges when used in conjunction with the manufacturer-provided helical driver torque chart. Other methods of directly measuring final installation torque include a calibrated load cell, PT-tracker or shear pin indicator.

The ultimate axial tension soil capacity of the $3\frac{1}{2}$ -inch-diameter pile must not exceed 89.6 kips (398.6 kN) or a maximum allowable axial tension load of 44.8 kips (199.3 kN).

The lateral capacity of the pile referenced in Section 4.1.1.2 and Table 1 of this report is based on field testing of the $2\frac{7}{8}$ -inch-diameter (73 mm) or the $3\frac{1}{2}$ -inch-diameter helical pile with a single 8-inch-diameter (203 mm) helix plate installed in a firm clay soil, having an average standard penetration test blow count of 20, at a minimum embedment of 15 feet (4.57 m). For soil conditions other than firm clay, the lateral capacity of the pile must be determined by a registered design professional.

4.1.2 Driven Pile: Structural calculations and drawings, prepared by a registered design professional, must be submitted to the code official for each project, based on accepted engineering principles, as described in 2012 and 2009 IBC Section 1810 and 2006 IBC Section 1808. The design method for steel components is Allowable Strength Design (ASD), described in IBC Section 1602 and AISC 360 Section B3.4. The structural analysis must consider all applicable internal forces (shear, bending moments and torsional moments, if applicable) due to applied loads, structural eccentricity and maximum span(s) between hydraulically driven steel pilings. The minimum embedment

depth for various loading conditions must be included based on the most stringent requirements of the following: engineering analysis, allowable capacities noted in this report, site-specific geotechnical investigation report, and site-specific load tests, if applicable. For driven steel foundation systems subject to combined lateral and axial (compression or tension) loads, the allowable strength of the shaft under combined loads must be determined using the interaction equation prescribed in Chapter H of AISC 360. A soil investigation report in accordance with Section 4.1.1 of this report must be submitted for each project. The soil interaction capacity between the pile and the soil and the soil effects of the driven installation must be determined by a registered design professional. A minimum safety factor of 3 must be applied to the hydraulically driven pile system. The maximum installation force and working capacity of the driven pile system must be determined in accordance with Ram Jack's installation instructions and as recommended by a registered design professional.

4.2 Installation:

The Ram Jack® Foundation Systems must be installed by Ram Jack® Manufacturing LLC certified and trained installers. The Ram Jack® foundation systems must be installed in accordance with this section (Section 4.2) and the manufacturer's installation instructions. For tension application, the helical pile must be installed such that the minimum depth from the ground surface to the uppermost helix is 12D, where D is the diameter of the largest helix. Helical piles used in tieback applications (retaining wall) must be installed with a minimum embedment of 12D (where D is the diameter of the uppermost helical plate), measured below the ground surface and behind the angle of repose or the active soil wedge, which is the horizontal distance between the intersection of the tieback and the active sliding surface and the center of the uppermost helical plate, when the retained slope (surface) is vertical. All field-cut or drilled pilings must be protected from corrosion as recommended by the registered design professional. Installation of helical piles must comply with Section 4.2.2 of this report and 2012 and 2009 IBC Section 1810.4.11.

4.2.1 Hydraulically Driven Steel Piling/Pier Installation:

1. An area must be excavated immediately adjacent to the building foundation to expose the footing, bottom of grade beam, stem wall or column to a width of at least 24 inches (610 mm) and at least 12 inches (305 mm) below the bottom of the footing or grade beam.
2. The vertical and bottom faces of the foundation must, to the extent possible, be smooth and at right angles of each other for the mounting of the pile bracket. The surfaces in contact with the support bracket must be free of all dirt, debris and loose concrete so as to provide firm bearing surfaces. Reference Figure 3 for proper bracket placement.
3. The spread footing, if applicable, must be notched to allow the support bracket seat to mount directly under the bearing load of the stem or basement wall.
4. The pile lead section, guide sleeve and first pile section must be inserted through the bracket sleeve. The double action hydraulic rams must be connected to the support bracket. The pile should not be more than 1 degree from vertical. Hydraulic rams used to install the pile must have the capability of exerting a minimum installation force of 60,000 lbs (267 kN).

5. The hydraulic rams must be reciprocated up and down, with the pile being advanced with each downward stroke. Pile sections must be continuously added as required to advance the pile through unstable soils as required. Advancement of the pile will continue until one of the following occurs: the structure begins to experience uplift flexure as the pile is being advanced, the desired hydraulic pressure is achieved or as determined by the foundation investigation. All piles must be installed individually utilizing the maximum resistance of the structure as a reaction force to install each pile. The location of the driven pile system must be determined by a registered design professional. Lifting of the structure must be verified by the registered design professional to ensure that the foundation and/or superstructure are not overstressed.
6. After piling termination, the excess piling must be cut off squarely at a sufficient height to allow for foundation lifting. The support strap assembly must be installed with the hex nuts, and the lifting tool is placed on the head of the pile.
7. The excavation must be back-filled and the soil properly compacted. Excess soil must be removed.

4.2.2 Helical Pile Installation:

1. An area must be excavated immediately adjacent to the building foundation to expose the footing, bottom of grade beam, stem wall or column to a width of at least 24 inches and at least 12 inches below the bottom of the footing or grade beam.
2. The vertical and bottom faces of the footing or grade beam must, to the extent possible, be smooth and at right angles to each other for the mounting of the support bracket. The surfaces in contact with the support bracket must be free of all dirt, debris and loose concrete so as to provide firm bearing surfaces.
3. The spread footing or grade beam, if applicable, must be notched to allow the support bracket seat to mount directly under the bearing load of the stem or basement wall.
4. A hydraulic torque driver head is used to install the helical pile. A helical lead section which has helical plates attached is installed first. The helical lead section must be pinned to the rotary torque driver and advanced into the ground by rotating the helical pile. Additional extension shafts must be added as required to advance the pile through unstable soils as required to bear in a load-bearing stratum. The support bracket can be placed on the pile after the lead section and any extensions with helical plates have been embedded into the soil. The remaining pile extensions can be installed through the bracket sleeve.
5. Advancement of the pile will continue until the minimum installation torque is achieved as specified by the torque correlation method to support the allowable design loads of the structure using a torque factor (K_t) of 9 ft^{-1} (29.5 m^{-1}) for the $2\frac{7}{8}$ -inch-diameter (73 mm) pile; or a K_t value of 7 ft^{-1} (22.9 m^{-1}) for the $3\frac{1}{2}$ -inch-diameter (89 mm) pile). The installation torque must not exceed 8,200 ft-lb (11 110 N-m) for the $2\frac{7}{8}$ -inch-diameter (73 mm) pile; or 14,000 ft-lb (18 967 N-m) for the $3\frac{1}{2}$ -inch-diameter (89 mm) pile.
6. After piling termination, the excess piling must be cut off squarely at a sufficient height to allow for foundation lifting. If the support bracket has not already been installed, it should be installed now. The support strap assembly must be installed on the support bracket, and the lifting tool placed on the head of the pile.
7. Lifting of the structure or proof loading of the pile can be performed using the hydraulic rams. Lifting of the structure must be verified by the registered design professional to ensure that the foundation and/or superstructure are not overstressed.
8. Once the foundation has been raised and/or stabilized, the nuts on the support strap assembly must be snug-tightened to secure the support strap and bracket to the pile. The lifting tool and hydraulics must then be removed.
9. The excavation must be back-filled and the soil properly compacted. Excess soil and any debris must be removed.

4.2.3 Floor Slab Bracket Helical Pile Installation:

1. A maximum 10-inch-diameter (254 mm) hole through the concrete floor slab must be core drilled and an area below the floor slab must be excavated to allow placement of the floor slab bracket.
2. A helical lead section must be inserted into the floor opening and pin-connected to the rotary torque driver. The pile must then be driven into the ground by rotating the helical pile. Additional extension shafts must be added as required to advance the pile through unstable soils as required to bear in a load-bearing stratum. The support bracket can be placed on the pile after the lead section and any extensions with helical plates have been embedded into the soil. The remaining pile extensions can be installed through the bracket sleeve or the bracket can be placed on the pile after the pile installation is terminated.
3. Advancement of the pile continues until the minimum installation torque is achieved as specified by the torque correlation method to support the allowable design loads of the structure using a torque factor (K_t) of 9 ft^{-1} (29.5 m^{-1}) for the $2\frac{7}{8}$ -inch-diameter (73 mm) pile. The installation torque must not exceed 8,200 ft-lb (11 110 N-m).
4. After piling termination, the excess piling must be cut off at a sufficient height to allow for foundation lifting. If the support bracket has not already been installed, it should be installed now. The support strap assembly must be installed on the support bracket, and the lifting tool placed on the head of the pile. Lifting of the structure must be verified by the registered design professional to ensure that the foundation and/or superstructure are not overstressed.
5. Lifting of the structure or proof loading of the pile may be performed using a hydraulic ram or as otherwise approved by the registered design professional and the code official.
6. Once the floor slab has been raised and/or stabilized, the nuts on the support strap assembly must be snug-tightened to secure the support strap and bracket to the pile. The lifting tool and hydraulic ram must then be removed.
7. The excavation must be back-filled and the concrete replaced in accordance with the registered design professional specifications. Excess soil and any debris must be removed.

4.2.4 New Construction Helical Pile Installation:

1. The lead helical section must be installed and successive extensions must be added as needed until the desired torque and capacity are achieved.
2. The pile must be cut squarely to the desired height upon termination of the pile.
3. The new construction bracket is placed over the top of the pile. If the pile is to be used to resist tension forces, the new construction bracket must be embedded the proper distance into the footing or grade beam as required to resist the tension loads as determined by a registered design professional, and must be through-bolted to the pile. Reference Table 4B for the proper embedment of the pile into the footing or grade beam for tension resistance.
4. Steel reinforcement bars are placed and tied to the bracket if applicable. The concrete is then placed according to the construction documents.

4.2.5 Tie-back Bracket Installation:

1. Excavate soil on the earth side of the retaining wall to an appropriate depth where the helical tieback will be installed.
2. Core drill a maximum 6-inch-diameter hole through the wall at the tieback location.
3. Insert extension through the hole in the wall and connect to lead section on opposite side of wall.
4. Connect torque driver to other end of the extension, align the tieback to the appropriate inclination as shown on the approved drawings, and begin rotating the tieback into the soil.
5. Advancement of the tieback continues until the minimum installation torque is achieved as specified by the torque correlation method to support the allowable design loads of the structure using a torque factor (K_t) of 9 ft^{-1} (29.5 m^{-1}) for the $2\frac{7}{8}$ -inch-diameter (73 mm) pile. The installation torque must not exceed 8,200 ft-lbs.
6. Cut the tieback shaft off squarely on the earth-retained side of the wall. Insert the all-thread connector through the hole in the wall and through-bolt the sleeve of the connector to the tieback shaft.
7. Use low slump grout to fill hole in wall. Place wall channel and wedge washer over all-thread and snug-tighten nut. Do not apply a tension force to the wall until the grout has cured to a sufficient strength as approved by a registered design professional.

4.3 Special Inspection:

Continuous special inspection in accordance with 2012 IBC Section 1705.9, 2009 IBC Section 1704.10, and 2006 IBC Section 1704.9 is required for installation of the Ram Jack® Helical Pile foundation system. Where on-site welding is required, special inspection in accordance with 2012 IBC Section 1705.2 and 2009 and 2006 IBC Section 1704.3 is required. The special inspector must verify the following:

1. Verification of manufacturer product model numbers (see Table 1).
2. Types, configurations and identifications of helical pier lead sections, pilings, extensions, brackets, bolts and torque as specified in this report and the construction documents.
3. Installation procedures, anticipated and actual piling depth.

4. Required target installation torque of piles and depth of the helical foundation system.
5. Inclination and position of helical piles; hub of pile extension in full contact with bracket; full-surface contact of foundation brackets with concrete; tightness of all bolts; and evidence that the helical pile foundation systems are installed by an approved Ram Jack® installer.
6. Compliance of installation with the approved geotechnical report and construction documents and this evaluation report.

5.0 CONDITIONS OF USE

The Ram Jack® Foundation Systems described in this report comply with, or are suitable alternatives to what is specified in, those codes indicated in Section 1.0 of this report, subject to the following conditions:

- 5.1** The foundation systems are manufactured, identified and installed in accordance with this report, the approved construction documents and the manufacturer's published installation instructions. In the event of a conflict between this report, the approved construction documents and the manufacturer's published installation instructions, the most restrictive governs.
- 5.2** Helical pile and driven pile systems have been evaluated to support structures in Seismic Design Categories (SDCs) A, B and C. Use of the systems to support structures assigned to SDC D, E or F, or which are located in Site Class E or F, are outside the scope of this report and are subject to the approval of the building official, based upon submission of a design in accordance with the code by a registered design professional.
- 5.3** Installation of the helical pile and hydraulically driven pile systems must be limited to support of uncracked normal-weight concrete, as determined in accordance with the applicable code.
- 5.4** Both the repair bracket and the new construction bracket must be used only to support structures that are laterally braced as defined in 2012 and 2009 IBC Section 1810.2.2 and 2006 IBC Section 1808.2.5.
- 5.5** The helical pile and hydraulically driven pile systems must not be used in conditions that are indicative of a potential pile corrosion situation as defined by soil resistivity of less than 1000 ohm-cm, a pH of less than 5.5, soils with high organic content, sulfate concentrations greater than 1000 ppm, landfills, or mine waste.
- 5.6** Zinc-coated steel and bare steel components must not be combined in the same system. All helical foundation components must be galvanically isolated from concrete reinforcing steel, building structural steel, or any other metal building components.
- 5.7** The helical piles must be installed vertically into the ground with a maximum allowable angle of inclination of 1 degree. To comply with the requirements found in Section 1810.3.1.3 of the 2012 and 2009 IBC (Section 1808.2.8.8 of the 2006 IBC), the superstructure must be designed to resist the effects of helical pile eccentricity.
- 5.8** Special inspection is provided in accordance with Section 4.3 of this report.
- 5.9** Engineering calculations and drawings, in accordance with recognized engineering principles and design

parameters as described in IBC Section 1604.4, and in compliance with Section 4.1 of this report, are prepared by a registered design professional and approved by the building official.

- 5.10 A soils investigation for each project site must be provided to the building official for approval in accordance with Section 4.1.1 of this report.
- 5.11 In order to avoid group efficiency effects, an analysis prepared by a registered design professional must be submitted where the center-to-center spacing of axially loaded helical piles is less than three times the diameter of the largest helix plate at the depth of bearing. An analysis prepared by a registered design professional must also be submitted where the center-to-center spacing of laterally loaded helical piles is less than eight times the least horizontal dimension of the pile shaft at the ground surface. Spacing between helical plates must not be less than 3D, where D is the diameter of the largest helical plate measured from the edge of the helical plate to the edge of the helical plate of the adjacent helical pile; or 4D, where the spacing is measured from the center-to-center of the adjacent helical pile plates.
- 5.12 Connection of the side load bracket or the repair bracket as it relates to seismic forces and the provisions found in 2012 and 2009 IBC Sections 1810.3.11.1 and 1810.3.6.1 and 2006 IBC Section 1808.2.23.1, and for all buildings under 2012 and 2009 IBC Section 1810.3.6 (second paragraph) and 2006 IBC Section 1808.2.7, are outside the scope of

this evaluation report. Compliance must be addressed by the registered design professional for each site, and the work of the design professional is subject to approval by the code official.

- 5.13 Settlement of the helical pile is outside the scope of this evaluation report and must be determined by a registered design professional as required in 2012 and 2009 IBC Section 1810.2.3 and 2006 IBC 1808.2.12.
- 5.14 The interaction between the hydraulically driven pile system and the soil is outside the scope of this report.
- 5.15 The Ram Jack® Foundation Systems are manufactured at the Ram Jack Manufacturing, LLC, facility located in Ada, Oklahoma, under a quality control program with inspections by CTL-Thompson. (AA-735).

6.0 EVIDENCE SUBMITTED

Data in accordance with the ICC-ES Acceptance Criteria for Helical Foundation Systems and Devices (AC358), dated June 2013 .

7.0 IDENTIFICATION

The Ram Jack® Foundation System components are identified by a tag or label bearing the Ram Jack logo, the name and address of Gregory Enterprises, Inc., the catalog number, the product description, the evaluation report number (ESR-1854), and the name of the inspection agency (CTL-Thompson, AA-735).

TABLE 1—FOUNDATION STRENGTH RATINGS OF BRACKETS³

PRODUCT NUMBER	DESCRIPTION	PILING DIAMETER (inches)	ALLOWABLE CAPACITY (kips)		
			Compression	Tension	Lateral
4021.1	Side load bracket	2 ⁷ / ₈	33.65 ^{1,5}	N/A	N/A
4021.55	Side load bracket	3 ¹ / ₂	55.12 ^{1,5}	N/A	N/A
4038.1	Side load bracket	2 ⁷ / ₈	19.70 ^{1,5}	N/A	N/A
4039.1	Side load bracket	2 ⁷ / ₈	32.07 ^{1,5}	N/A	N/A
4075.1	New construction	2 ⁷ / ₈	See Table 3A	See Table 3B	1.49 ^{2,5}
4079.1	New construction	2 ⁷ / ₈	See Table 3A	See Table 3B	1.49 ^{2,5}
4076	New construction	3 ¹ / ₂	See Table 3A	See Table 3B	2.79 ^{2,5}
4093.1	Slab bracket	2 ⁷ / ₈	See Table 5	N/A	N/A
4550.2875.1	Tieback assembly	2 ⁷ / ₈	27.9 @ 20° angle (tension only) ^{4,5}		
			27.6 @ 30° angle (tension only) ^{4,5}		

For SI: 1 inch = 25.4 mm, 1 kip (1000 lbf) = 4.48 kN.

¹Load capacity is based on full scale load tests per AC358 with an installed 5'-0 unbraced pile length having a maximum of one coupling per 2012 and 2009 IBC Section 1810.2.1 and 2006 IBC 1808.2.9.2. A 4-foot-long guide sleeve must be installed at the top of the shaft as required in Figures 3, 5 and 7. Side load bracket must be concentrically loaded. Side load bracket plate must be fully engaged with bottom of concrete foundation. Only localized limit states such as mechanical strength of steel components and concrete bearing have been evaluated.

²Lateral load capacity is based on lateral load tests performed in firm clay soil per Section 4.1.1 of this report. For any other soil condition, the lateral capacity of the pile must be determined by a registered design professional. The bracket must be installed with minimum embedment of 3 inches when measured from the bottom of the concrete foundation to the bottom of the bracket plate. Minimum width of footing must be 12 inches.

³The capacities listed in Table 1 assume the structure is sidesway braced per 2012 and 2009 IBC Section 1810.2.2 and 2006 IBC Section 1808.2.5.

⁴Tieback assemblies must be installed in accordance with Section 4.2.5 of this report. Only localized limit states such as mechanical strength of steel components and concrete bearing have been evaluated. The tieback assembly must be installed to support a minimum 6-inch thick concrete wall. Two through bolts are required for connection between bracket sleeve and helical shaft. Bolts must be 3/4-inch diameter complying with ASTM A325 and installed snug-tight with threads excluded.

⁵The tabulated values are based on installation with normal-weight concrete having a minimum compressive strength of 2500 psi (17.23 MPa). N/A = not applicable.

TABLE 2—MECHANICAL PROPERTIES AFTER CORROSION LOSS¹ OF 2.875-INCH- AND 3.5-INCH-DIAMETER HELICAL SHAFT

Mechanical Properties	SHAFT DIAMETER	
	2.875	3.5
Steel Yield Strength, F_y (ksi)	65	65
Steel Ultimate Strength, F_u (ksi)	80	80
Modulus of Elasticity, E (ksi)	29,000	29000
Nominal Wall Thickness (inch)	0.217	0.254
Design Wall Thickness (inch)	0.1758	0.2102
Outside Diameter (inch)	2.8490	3.4740
Inside Diameter (inch)	2.4974	3.0536
Cross Sectional Area (inch ²)	1.48	2.16
Moment of Inertia, I (inch ⁴)	1.32	2.88
Radius of Gyration, r (inch)	0.95	1.16
Section Modulus, S (inch ³)	0.93	1.66
Plastic Section Modulus, Z (inch ³)	1.26	2.24

For **SI**: 1 inch = 25.4 mm; 1 ksi = 6.89 MPa, 1 ft-lbf =1.36 N-m; 1 lbf =4.45 N.

¹Dimensional properties are based on powder coated steel losing 0.026-inch steel thickness as indicated in Section 3.9 of AC358 for a 50-year service life.

TABLE 3A—ALLOWABLE LOAD CAPACITIES IN COMPRESSION FOR THE NEW CONSTRUCTION BRACKET

Bracket Number	Concrete 28-day Compressive Strength, psi	Overall Beam Depth, in.	Bracket Embedment Depth, (in)	Allowable Load Capacity of Minimally Reinforced Concrete ^{1,2} , (kips)
4075.1	2500	12	4	18.2
	3000	14	4	18.2
4079.1	2500	12	4	36.5
	3000	14	4	36.5
4076.1	2500	14	4	49.5
	3000	14	4	54.2

For **SI**: 1 inch = 25.4 mm; 1 kip (1000 lbf) = 4.48 kN; 1 psi = 6.89 kPa.

¹The allowable load capacities have been determined assuming that minimum reinforcement has been provided as specified by ACI 318 Section 10.5.1. Embedment depth is measured from the top of the concrete beam to the top of the bracket plate. The allowable capacities are based on installation with normal-weight concrete. Only localized limit states such as mechanical strength of steel components, concrete bearing and punching shear capacity have been evaluated.

²New construction bracket must be installed with the bracket plate fully bearing with the end of the pile shaft.

TABLE 3B—ALLOWABLE LOAD CAPACITIES IN TENSION FOR THE NEW CONSTRUCTION BRACKET

Bracket Number	Concrete 28-day Compressive Strength, (psi)	Beam Depth, (in)	Embedment Depth of Bearing Plate, (in)	Effective Depth, (in)	Allowable Load Capacity for Minimally Reinforced Concrete ^{1,2} (kips)	Number of Through Bolts ³
4075.1	2500	12	5	1.75	5.25	1
		12	7	3.75	15.29	1
		12	9	5.75	18.20	1
	3000	12	5	0.75	5.75	1
		12	7	2.75	16.75	1
		12	9	4.75	18.20	1
4079.1	2500	12	5	1.75	5.99	1
		12	7	3.75	18.47	1
		12	9	5.75	31.06	2
		14	6	2.75	12.15	1
		14	8	4.75	24.66	1
		14	9	5.75	31.06	2
	3000	14	10	6.75	36.5	2
		12	5	1.75	6.56	1
		12	7	3.75	20.23	1
		12	9	5.75	36.5	2
4076.1	2500	16	7	3.75	20.04	1
		16	9	5.75	34.68	2
		16	11	7.75	47.20	2
4076.1	3000	14	7	3.75	21.95	1
		14	9	5.75	37.99	2
		14	10	6.75	46.16	2

For **SI**: 1 inch = 25.4 mm; 1 kip (1000 lbf) = 4.48 kN; 1 psi = 6.89 kPa.

¹The load capacities have been determined based on a 12-inch wide grade beam. Effective depth is defined as the distance between the embedment depth of the bearing plate subtracted from the reinforcement cover depth. Embedment depth is defined as the distance between the bottom of the concrete beam and the bottom of the bracket plate.

²The grade beam is assumed to be minimally reinforced as required by ACI 318 Section 10.5.1. The allowable capacities are based on installation with normal-weight concrete. Only localized limit states such as mechanical strength of steel components, concrete bearing and punching shear capacity have been evaluated.

³Number of through bolts required for connection between bracket sleeve and helical shaft. Bolts must be 3/4-inch diameter complying with ASTM A325 and installed snug-tight with threads excluded.

TABLE 4A—ALLOWABLE COMPRESSION CAPACITY OF 2 7/8-INCH-DIAMETER PILE WITH COUPLER ECCENTRICITY³ (kips)

	Fully Braced (L _u = 0)	kL _u = 4 ft ¹	kL _u = 8 ft ¹
0 couplings (no eccentricity)	57.47	45.02	21.60
1 coupling ²	57.47	28.68	18.38
2 coupling ²	57.47	N/A	11.81

For **SI**: 1 inch = 25.4 mm; 1 ft = 0.305 m; 1 kip (1000 lbf) = 4.48 kN.

¹L_u=unbraced length per 2012 and 2009 IBC Section 1810.2.1 and 2006 IBC Section 1808.2.9.2

²Number of couplings within L_u

³The capacities shown in Table 5A are for 2 7/8-inch-diameter pilings installed with a maximum 1 degree of inclination and do not require the installation of an external guide sleeve. The capacities are also based on the assumption that the pile shaft is concentrically loaded.

TABLE 4B—ALLOWABLE COMPRESSION CAPACITY OF 3 1/2-INCH-DIAMETER PILE WITH COUPLERS³ (kips)

	Fully Braced (L _u = 0)	kL _u = 4 ft ¹	kL _u = 8 ft ¹
0 couplings	60	44.3	30.1
1 coupling ²	60	44.3	30.1
2 coupling ²	60	44.3	30.1

For **SI**: 1 inch = 25.4 mm; 1 ft = 0.305 m; 1 kip (1000 lbf) = 4.48 kN.

¹L_u=unbraced length per 2012 and 2009 IBC Section 1810.2.1 and 2006 IBC Section 1808.2.9.2

²Number of couplings within L_u

³The capacities shown in Table 5B are for 3 1/2-inch-diameter pilings installed with a maximum 1 degree of inclination from vertical and do not require the installation of an external guide sleeve. The capacities are also based on the assumption that the pile shaft is concentrically loaded.

TABLE 5—ALLOWABLE COMPRESSIVE LOAD CAPACITY RATING OF RAM JACK’S # 4093 SLAB BRACKET SUPPORTING MINIMALLY REINFORCED NORMAL WEIGHT CONCRETE SLAB^{1,2}
(Max. load rating = 11.7 kips)

Concrete 28-day Compressive Strength, f'c (psi)	Concrete Floor Slab Depth (t) (in)	Minimum Area of steel reinforcement in Concrete Slab ¹ , A _{s,min} (in ²)	Live Load (psf)	Maximum Pile Spacing		Pile Load (kip)	
				1 & 2 Span	3 Span	1 & 2 Span	3 Span
2,500	4 ⁴	0.06	40	4'-10"	5'-5"	2.12 k	2.65 k
			50	4'-6"	5'-1"	2.08 k	2.60 k
			100	3'-7"	4'-0"	1.99 k	2.49 k
	5 ⁴	0.075	40	5'-8"	6'-4"	3.36 k	4.20 k
			50	5'-5"	6'-0"	3.31 k	4.14 k
			100	4'-4"	4'-11"	3.15 k	3.94 k
	6	0.09	40	6'-6"	7'-3"	4.90 k	6.13 k
			50	6'-2"	6'-11"	4.83 k	6.03 k
			100	5'-1"	5'-8"	4.59 k	5.74 k
	8 ³	0.12	40	8'-8"	9'-1"	10.61 k	11.70 k
			50	8'-3"	8'-9"	10.30 k	11.70 k
			100	6'-9"	7'-7"	9.34 k	11.67 k
3,000	4 ⁴	0.066	40	5'-1"	5'-8"	2.33 k	2.91 k
			50	4'-9"	5'-4"	2.29 k	2.86 k
			100	3'-9"	4'-3"	2.19 k	2.73 k
	5 ⁴	0.082	40	6'-0"	6'-8"	3.69 k	4.62 k
			50	5'-8"	6'-4"	3.64 k	4.54 k
			100	4'-7"	5'-2"	3.46 k	4.33 k
	6	0.098	40	6'-10"	7'-7"	5.39 k	6.73 k
			50	6'-6"	7'-3"	5.30 k	6.63 k
			100	5'-4"	6'-0"	5.05 k	6.31 k
	8 ³	0.131	40	9'-1"	9'-2"	11.66 k	11.70 k
			50	8'-8"	8'-9"	11.31 k	11.70 k
			100	7'-1"	7'-7"	10.26 k	11.70 k

For SI: 1 inch = 25.4 mm; 1 kip (1000 lbf) = 4.48 kN; 1 psi = 6.89 kPa; 1 psf = 47.88 Pa.

¹The maximum pile spacing shown are for floor slabs constructed of normal weight concrete (150 pcf) with minimum reinforcement (f_y = 60 ksi) per ACI 318 Section 10.5.1.

²The maximum floor slab spans shown assumes the minimum floor slab reinforcement is placed in the center of the slab (t/2). Longer spans can be achieved if the slab reinforcement is proven to be larger and/or placed below the central line of the floor slab. Structural calculations must be submitted for approval by a registered design professional for spans greater than those shown for a reinforced floor slab.

³The maximum load rating of the 4093 slab bracket controls the pile spacing.

⁴The spans and pile loads shown for the 4-inch and 5-inch thick floor slab assumes the floor slab are being placed on a vapor barrier. Per Section 7.7.1 of ACI 318, the minimum concrete cover required is 1½ inches. This table should not be used for the 4-inch and 5-inch thick floor slabs placed directly on soil, where the minimum concrete cover is 3 inches, which places the reinforcement above the neutral axis. Table 7 should be used for the 4 inch and 5 inch thick concrete slab cast directly on soil.

TABLE 6—ALLOWABLE TENSION AND COMPRESSION LOADS FOR HELICAL PLATES (KIPS)

Helical Plate Diameter ¹ (inches)	Helical Pile Shaft Diameter (inches)	
	2 ⁷ / ₈	3 ¹ / ₂
8	63.29	79.84
10	55.51	66.29
12	39.40	65.74
14	42.07	60.42

For SI: 1 inch = 25.4 mm; 1 kip = 1000 lbf = 4.45 kN.

¹Allowable load values are for helical plates made from 3⁸/₁₆-inch thick steel, except for the 14-inch diameter plate, which is made from ½-inch thick steel.

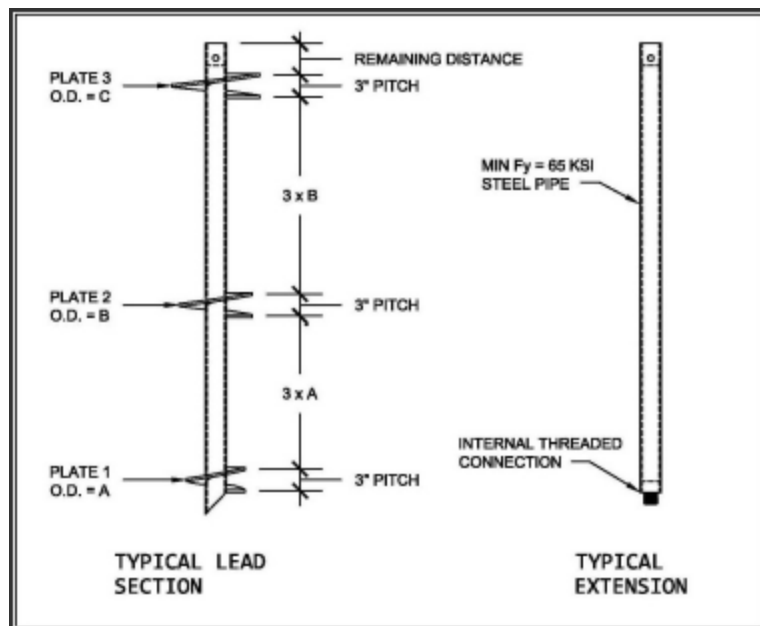

FIGURE 1—TYPICAL HELICAL PILE AND PLATE SPACING CHARACTERISTICS

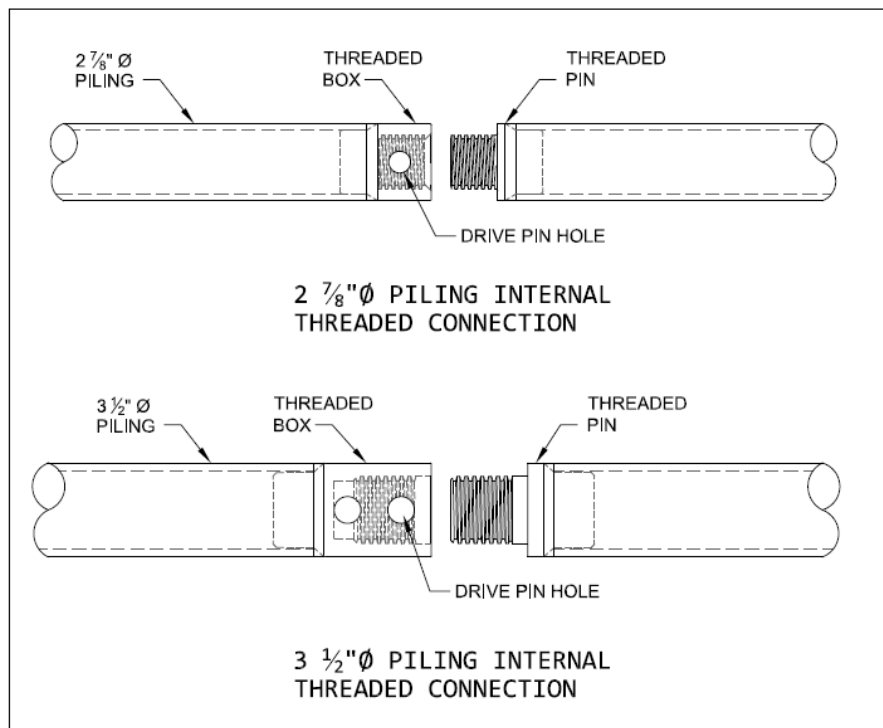

FIGURE 2—TYPICAL HELICAL PILE SYSTEM INTERNAL THREADED CONNECTION DETAIL

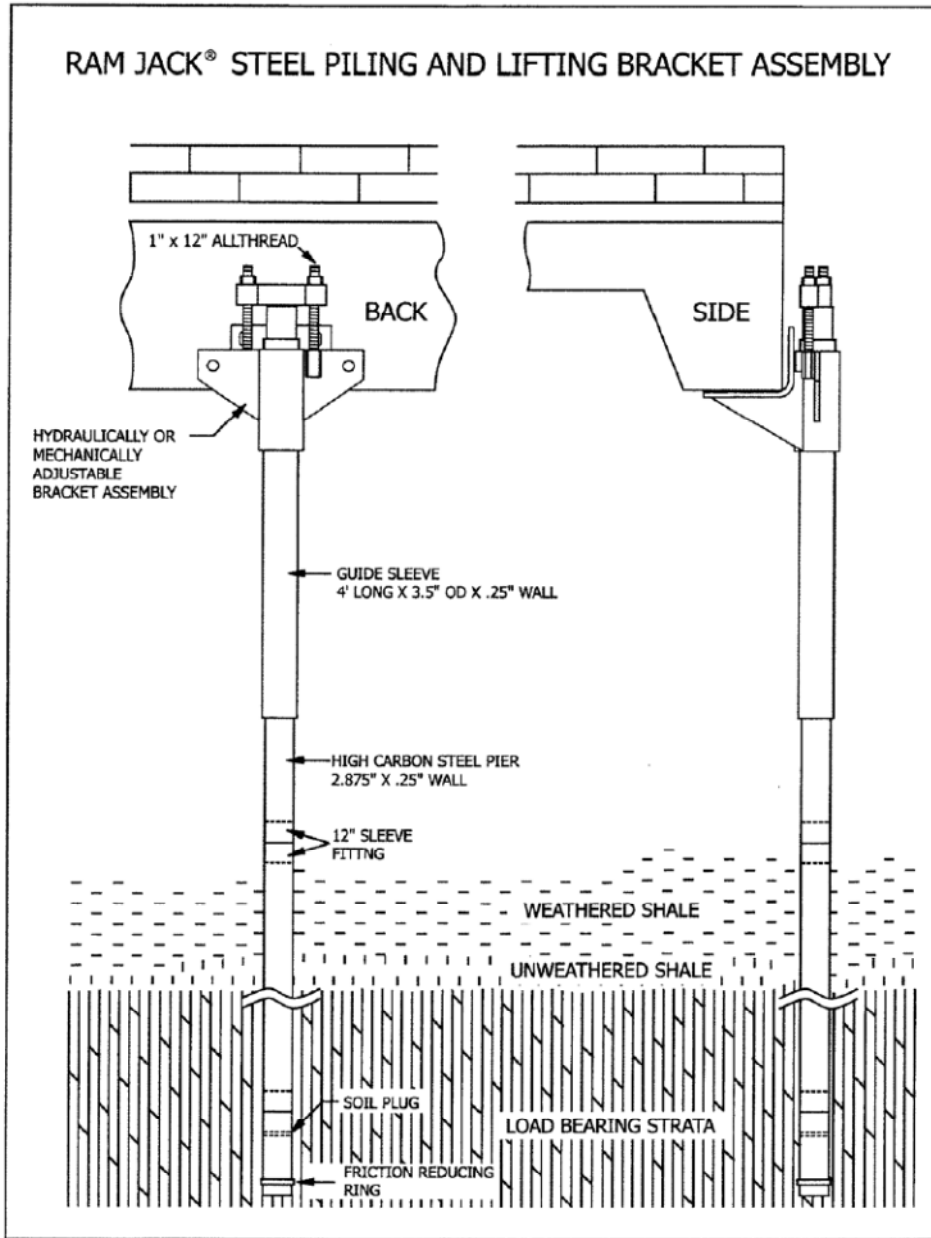

FIGURE 3—TYPICAL DRIVEN PILING USED IN CONJUNCTION WITH THE COMMERCIAL BRACKET #4021

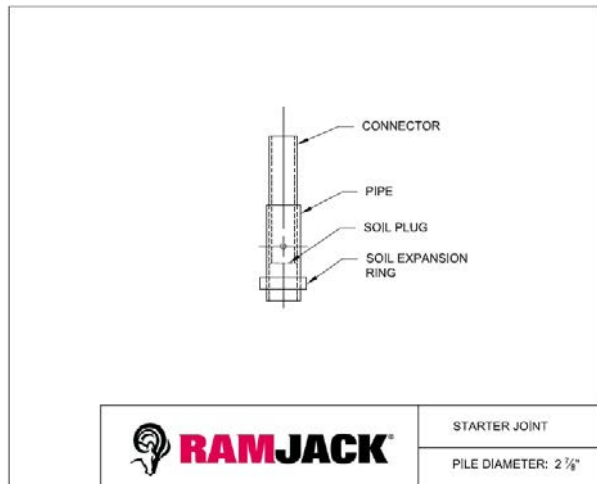

FIGURE 4—DETAIL OF STARTER JOINT

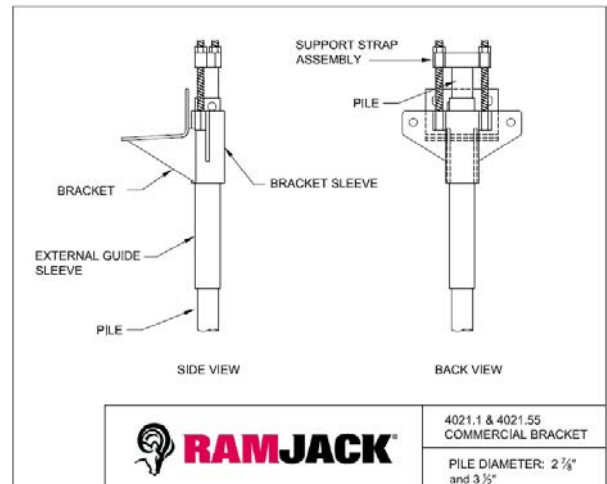

FIGURE 5—4021.1 SUPPORT BRACKET ASSEMBLY WITH GUIDE SLEEVE AND PILING

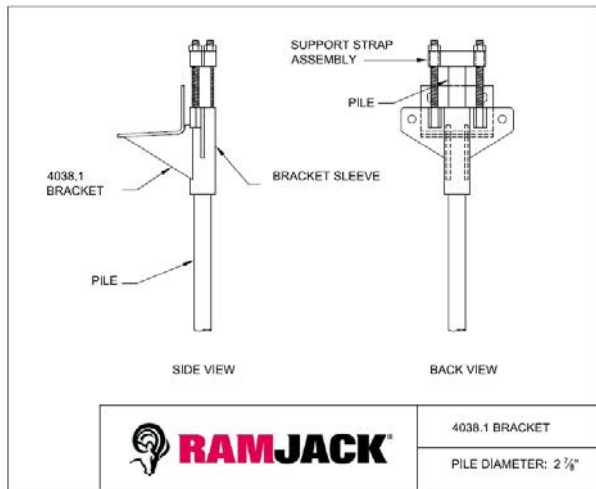

FIGURE 6—4038.1 SUPPORT BRACKET AND PILING

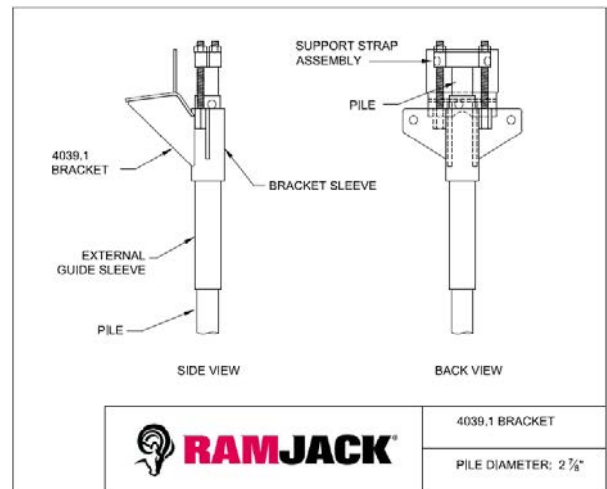

FIGURE 7—4039.1 SUPPORT BRACKET AND PILING

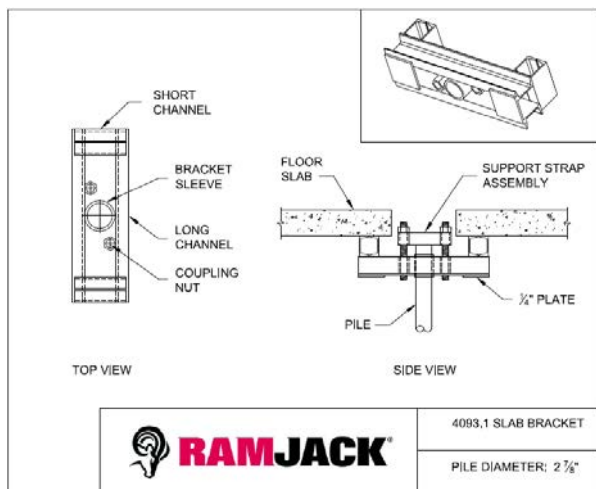

FIGURE 8—4093.1 FLOOR SLAB BRACKET AND PILING

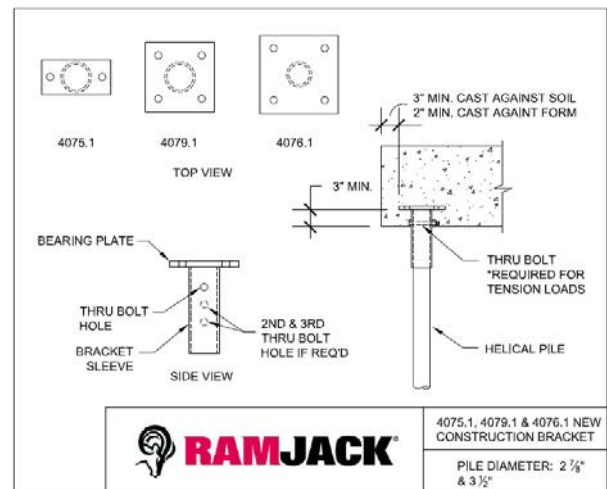

FIGURE 9—4075.1 AND 4079.1 NEW CONSTRUCTION BRACKETS

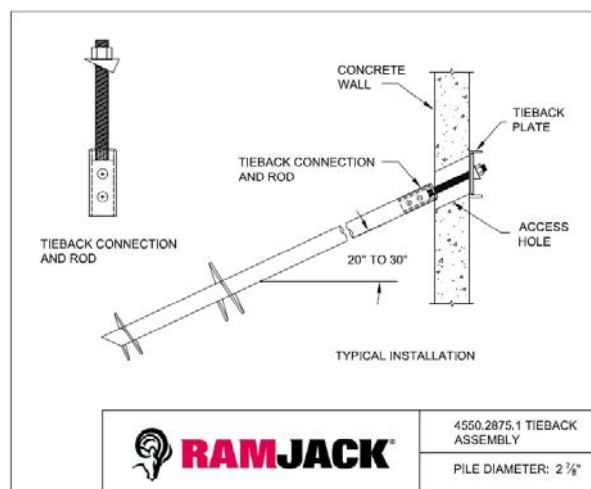

FIGURE 10—4550.2875.1 TIEBACK ASSEMBLY